

SIREP

WIB

EXERA

International Instrument Users' Associations

Intelligent Temperature Transmitter STT25H

Manufacturer: Honeywell SA, France

Published by SWE, July 2000

Index Classification: 2.2

Report no.: E 2706 I 00



Members of the International Instrumentation Evaluation Agreement Group of the European Organisation for Testing and Certification (EOTC) • Registration No 003

CIRCULATION

This report has been produced for the in-house use of SIREP, WIB and EXERA members. The contents of the report must not be divulged by them to persons not employed by SIREP, WIB or EXERA member companies without the express consent of the issuing organisation.

The manufacturer of the instrument has the right to use this report in its entirety for commercial or promotional purposes.

ABOUT SIREP-WIB-EXERA

SIREP-WIB-EXERA are international instrument users' associations who collaborate in the sponsoring, planning and organisation of instrument evaluation programmes. They have the long term objective of encouraging improvements in the design, construction, performance and reliability of instrumentation and related equipment.

SIREP-WIB-EXERA are formally recognised by the European Organisation for Testing and Certification (EOTC) as the Agreement Group for International Instrumentation Evaluation, Registration No 0003.

The evaluation of the selected instruments is undertaken by approved, independent laboratories with respect to the manufacturers' performance specifications and to the relevant international and national standards.

Each evaluation report describes the assessment of the instrument concerned and the results of the testing. No approval or certification is intended or given. It is left to the reader to determine whether the instrument is suitable for its intended application. All reports are circulated throughout the entire membership of SIREP-WIB-EXERA.

SIREP International Instrument Users' Association
South Hill, Chislehurst, Kent, England BR7 5EH

International Instrument Users' Association **WIB**
Prinsessegracht 26, 2514 AP, The Hague, The Netherlands

EXERA Association des Exploitants d'Equipements de Mesure, de Regulation et
d'Automatisme
Parc Technologique ALATA, BP 2,
F-60550 Verneuil en Halatte, France

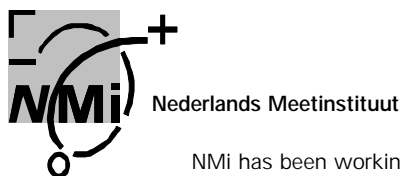

NMI has been working in the field of metrology for over 100 years and has built up an international reputation, with establishments in The Netherlands and Japan (Kawasaki). NMI is an independent institute for testing & certification, calibration, training and consultancy in metrology and technology. NMI is member of various international committees including Bureau International des Poids et Mesures (BIPM), the Organisation Internationale de Métrologie Légale (OIML), Euromet, Eurachem, Eurolab and the European Accreditation of Laboratories (EAL). Product evaluations is one of the main activities of NMI. These evaluation are performed against manufacturers or customers specifications, legal requirements (e.g. Weights & Measures Act, European CE marking) or recommendations (e.g. OIML). Besides product certification NMI is accredited by RvA for certification according to the ISO 9000 series. For manufacturers of measuring and weighing equipment, gaming machines, telecommunications, radio equipment and electronics NMI can offer one-stop-shopping (EMC, Electrical Safety, Metrology, Calibrations, Training etc...).

Subject : TESTS ON INTELLIGENT TEMPERATURE TRANSMITTER TYPE STT25H
Ranges: -200 °C .. 850 °C (RTD sensor)
-200 °C .. 1200 °C (J-thermocouple)

Manufacturer : Honeywell SA, France

Report N° : E 2706 I 00

NMI project N° : 10098822

Index classification : 2.2

Sponsor : International Instrument Users' Association – WIB and the manufacturer

Author : J.C.M. v.d. Berg

Nederlands Meetinstituut
Postbus 394
3300 AJ Dordrecht (NL)
Hugo de Grootplein 1
3314 EG Dordrecht
Telephone + 31 78 6 332 332
Telefax + 31 78 6 332 309
E-mail NMI@NMI.nl

Nederlands Meetinstituut B.V.
(Registered at the Chamber of Commerce Delft
number 28701)

Offices: Delft, Dordrecht, Niekerk, Utrecht,
Kawasaki (Japan)

Subsidiary companies:
NMI Certin B.V. (33418)
NMI Van Swinden Laboratorium B.V. (28703)

Reg. nr. L 029

SIREP-WIB-EXERA
MEMBERSHIP LIST
2000

Acetex Chimie (*)	Institut de Recherche de la Sidérurgie
Aérospatiale	Institut National de Recherche et de Sécurité
Agences de Bassin	Italcementi / CTG
Air Liquide	Jacobs Comprimo Nederland BV (*)
Air Products & Chemicals Incorporated	KEMA Nederland BV
Akzo Nobel Engineering	Lubrizol France (*)
BP Amoco	Lyonnaise des Eaux
Bellt GCA(*)	Magnox Electric plc
British Energy plc	Mobil Research & Development Corporation
CEA	Mossgas (Pty) Ltd
Centre d'Essais des Propulseurs	Nancié (*)
Centre d'Essais en Vol	National Power plc
Chiyoda Corporation	Nederlands Meetinstituut
Compagnie Générale des Matières Nucléaires	NV Nederlandse Gasunie
Corus Group plc	Nestec Ltd
Danone (Branche "Produits Frais")	Process Management & Control (*)
Dassault Aviation (*)	PSA Peugeot-Citroen
DOW Benelux	Raytheon E&C BV (*)
DSM Services Engineering-Stamicarbon	Régie Autonome des Transports Parisiens
Dupont de Nemours BV-NL	Renault SA
EC Erdölchemie	Rhône Poulenc
ECN/Netherlands Energy Research Foundation (*)	Rijks Instituut voor Kust en Zee (RIKZ)
Ekono OY	Saint Louis Sucre
Electricité de France	Saudi Arabian Oil Company
Elf Antar	Severn-Trent Water Ltd
Elf (Groupe)	Shell Global Solutions
Ente Nazionale per l'Energia Elettrica	Snamprogetti
Enviroment Agency	Société Générale pour les Techniques Nouvelles
Esso Engineering Europe Ltd	Solvay BV Benelux
Exxon Research & Engineering Company	Stiftelsen for Instrumentprovning
Firmenich	Tec Ingénierie
Gaz de France	Technicatome
GEMCEA	Texaco Incorporated
Générale des Eaux	Thames Water Utilities Ltd
Glaxo Wellcome plc	TotalFina
GTIE	Toyo Engineering Corporation
Heineken Technical Services	Trapil
INERIS	
Infraserv Höchst	

(*) Associate Member

Contents

Section	Page
1. INTRODUCTION	1
2. MAJOR FINDINGS AND COMMENTS	4
2.1. Instrument performance	4
2.2. Comments on construction and use	7
2.3. Comments on documentation and identification	7
2.4. Manufacturer's comments	7
3. TESTS RESULTS	8
3.1. Results summary	8
3.1.1. Thermocouple transmitter	8
3.1.2. RTD transmitter	15
3.1.3. Graphs	19
4. MANUFACTURER'S DATA	25
5. OPERATING PRINCIPLE AND CONSTRUCTION	32
6. TEST METHODS AND REFERENCES	33
6.1. Test methods	33
6.2. References	42
6.3. Definitions	42

APPENDIX Manufacturer's QA-procedures and instrument status

MANUFACTURER'S LITERATURE

GRAPHS

<u>Number</u>	<u>Description</u>	Page
Graph 1.1, 1.2, 1.3	Accuracy tests, thermocouple transmitter	20
Graph 1.4, 1.5	Ambient temperature, thermocouple transmitter	21
Graph 1.6	Long term test, thermocouple transmitter	21
Graph 2.1, 2.2, 2.3	Accuracy tests, RTD transmitter	22
Graph 2.4, 2.5	Ambient temperature, RTD transmitter	23
Graph 2.6	Long term test, RTD transmitter	24
Graph 3.1	Output block	24



HONEYWELL SA TYPE STT25H INTELLIGENT TEMPERATURE TRANSMITTER

Author : J.C.M. v.d. Berg
Approved : ing. W.A.C.M. van Leeuwen

Evaluated by Nederlands Meetinstituut on behalf of International Instrument User's Association WIB and the manufacturer.

SIREP-WIB-EXERA report N° E 2706 I 00 NMI project nr. : 10098822
Index classification : 2.2

The full report comprises 40 pages; the abridged report comprises the first 7 pages of the full report.

July, 2000

1. INTRODUCTION

General

This report describes the evaluation of an Intelligent Temperature transmitter, used either with a thermocouple type J input and/or a Pt100 DIN/IEC sensor, manufactured by Honeywell SA. The instruments are standard production models, manufactured in France, and have the following characteristics:

Type	:	STT25H
Serial number	:	Test 1 (tc-setting range -180 ... + 760 °C only), 3, 4, 9, 10, 11, 15 and 18: 16000 Test 12 (Pt100 setting) and test13 (Pt100 setting): 2429 Test 16: 2409 Other tests: 2439
Range	:	Depending on input selection; refer to manufacturer's specifications sheet
Power supply (at terminals)	:	10.8 ... 35.0 Vdc
Output	:	4 ... 20 mA and HART
Damping	:	0 ... 32 s
Load resistance	:	0 Ω ... 1110 Ω
Process connections	:	M3 nickel plated brass screws
Suitable for	:	RTD's; thermocouples; millivolt input; resistance measurement
Specified accuracy	:	refer to the applying table in the manufacturer's specification sheet

The instruments were evaluated in accordance with the WIB test programme for temperature transmitters (version July 1999), except for the EMC-tests, the common mode test and the vibration test. The manufacturer has made available his internal EMC-conformity. The final test program was agreed upon with the WIB and the manufacturer.

With the exception of the input circuitry, all functions of the temperature transmitters are common for both the thermocouple configuration and the Pt100 configuration. Therefore, the Pt100 configuration was subjected to a limited test programme. The output block was tested separately.

Investigation history

First, one temperature transmitter, with the serial number 221568 was delivered to Nederlands Meetinstituut on April 28th, 1999. During testing the Pt100 calculation routines of this transmitter appeared to be faulty. Therefore, this transmitter was withdrawn from testing by the manufacturer. The calculation routine was corrected by the manufacturer, and implemented in a new series of transmitters. The type identification however remained unchanged.

Three new temperature transmitters instruments were delivered to Nederlands Meetinstituut on September 20, 1999, and evaluated in the laboratories of Nederlands Meetinstituut over the period of September 20th, 1999, up to January 19th, 2000. During this investigation, when performing the line resistance test (test 4) on the Pt100-application, an error was discovered. According to the manufacturer, this error was due to a design problem.

As a result of this, to overcome the problem, the manufacturer has improved the temperature transmitter. On this improved transmitter, delivered to Nederlands Meetinstituut on May 1st, 2000, in the period from May 26th, 2000 up to June 9th, 2000 the tests 1 (Pt 100-application fully; tc-application only for the range $-180\text{ }^{\circ}\text{C} \dots +740\text{ }^{\circ}\text{C}$); 3; 4; 9;10; 11; 15 and 18. Before carrying out these test, on request of the manufacturer, for both the Pt100-application and the thermocouple-application a calibration of the temperature transmitter was carried out by setting the parameters "Correct input LRV" and "Correct input URV".

The type identification of the transmitter remained unchanged.

Monthly the project progress was reported to the WIB. The draft report was issued in June 2000.

Instrument description

The model STT25H temperature transmitter is a microprocessor based device suitable for receiving a wide variety of mV or resistive sensors, such as thermocouples, RTD's (2, 3, and 4 wire), other resistive sensors and mV d.c. sources, and providing a mA output and a digital HART-output.

One 4-20 mA output is available, with superposed on this current a digital signal to communicate using the HART communication protocol. During the evaluation, all digital readings were determined using the HART signal, by means of a HART hand held terminal. The analog output values from the 4-20 mA output signal were calculated from the voltage reading over a known resistor.

The output current can be set to any discrete value using the hand held terminal.

The 4-20 mA output is updated 2 times a second; the HART digital output is updated 2 times a second.

The input and output characteristics of the instruments are determined by the configuration information as programmed in the transmitter. The instruments are configured remotely by a hand held terminal, which can communicate with the transmitter from any wiring termination point in the output loop. The communication is based on the Bell 202 or the Frequency Shift Keying (FSK) technique.

The configuration is stored in a non volatile memory.

The instrument's software provides continuous self-diagnostics.

The standard two-wire transmitter can be operated at a supply voltage from 10.8 Vdc to 35.0 Vdc at the terminals, providing 4 - 20 mA into a load of 0 ... 1110 Ω .

The tested transmitters were not equipped with an optional display.

During the tests, the range limits of the thermocouple input were 0 °C to 50 °C, unless otherwise specified. The specified accuracy including repeatability and linearity for the maximum test span (-180 °C ... + 760 °C) is in the digital mode ± 1.20 °C (0.128 % of the maximum test span). For the mA output the accuracy is ± 1.44 °C (0.153 % of the maximum test span). The minimum span to hold the noise within the accuracy specifications with damping at zero seconds is not specified. These accuracy figures apply to the use at a nominal environmental temperature of 20 °C.

During the tests, the range limits of the RTD input were 0 °C to 20 °C, unless otherwise specified. The specified accuracy including repeatability and linearity for the maximum span (-200 °C ... 850 °C) is in the digital mode ± 0.25 °C (0.024 % of span). For the mA output the accuracy is ± 0.52 °C (0.049 % of span). The minimum span to hold the noise within the accuracy specifications with damping at zero seconds is not specified. These accuracy figures apply to the use at a nominal environmental temperature of 20 °C.

The transmitter is designed to operate at ambient temperatures ranging from -40 °C to + 85 °C.

Damping was set to 5 seconds for all tests unless otherwise specified.

The transmitter meets the electrical safety requirements of various agencies. Refer to the manufacturer's specifications for detailed information.

2. MAJOR FINDINGS AND COMMENTS

These findings are summarised for ready reference and to give an overview of the evaluation. For a complete assessment of the instrument the report must be read and considered as a whole.

2.1 Instrument performance

Note: Unless otherwise stated all tests were completed with the thermocouple transmitter range set to 0 °C to 50 °C (turn down ratio, referenced to the maximum test span, 1 : 18.8) and the RTD transmitter range set to 0 °C to 20 °C (turn down ratio 1 : 52.5).

Unless otherwise stated all errors are quoted as a percentage of span.

2.1.1 Thermocouple transmitter

Test results which were within the manufacturer's specification

- During the accuracy test the following errors were found:

Input range	Type of indication	Average error %	Hysteresis %	Repeatability %	Specification including linearity and repeatability %
0 °C to 40 °C	Analog measurement	-1.262	0.135	0.189	± 2.025
0 ° to 500 °C		-0.139	0.014	0.055	± 0.185
-180 °C to +760 °C		-0.056	0.016	0.043	± 0.153

Input range	Type of indication	Average error %	Hysteresis %	Repeatability %	Specification including linearity and repeatability %
0 °C to 40 °C	Digital indication on hand held terminal, in °C	-1.291	0.185	0.272	± 2.000
0 ° to 500 °C		-0.099	0.009	0.046	± 0.160
-180 °C to +760 °C		-0.039	0.017	0.084	± 0.128

The resolution of the current output was 0.1 µA.

- Output load variations from 250 Ω to 1110 Ω measured at the maximum supply voltage of 35 Vdc (at the terminals) caused a zero shift of 0.080 % at 250 Ω and 0.023 % at 1110 Ω and a span shift of 0.222 % at 250 Ω and 0.253 % at 1110 Ω , all values with respect to the measured values at a load of 500 Ω.
- Power supply variations from 10.8 V (terminal voltage) to 35.0 V caused a zero shift of 0.056 % and a span shift of 0.126 % at a power voltage of 10.8 V and caused a zero shift of -0.124 % and a span shift of 0.004% at a power voltage of 35.0 V; all values with respect to the measurement at 24 Vdc.

At a supply voltage of 10.8 Vdc (terminal voltage) the output current is still within the error limits as specified by the manufacturer.

- During the ambient temperature test with two temperature cycles ranging from -40 °C to + 85 °C the following shifts were found:

	mA output		digital indication	
	Zero shift %	Span shift %	Zero shift %	Span shift %
Maximum shift at + 85 °C	-0.661	0.399	-0.677	-0.377
Maximum shift at -40 °C	1.681	1.584	1.689	1.660
Remaining shift after the test	0.130	0.233	0.005	0.273

The following effects of a series mode voltage were found:

U ac (mV)	Shift %
5	-0.180
6	-2.430
10	-2.351
35	-2.205
> 35	> 20

At an input of a 50 Hz 35 mV sine wave signal at the output no 50 Hz sine wave was detected.

Tests for which effects were not specified

- During the long term drift test for 30 days at a steady input of 90 % the maximum shift of the digital output (HHT) was 0.046 %.
- During the long term drift test for 30 days at a steady input of 90 % the maximum shift of the current output was 0.046%. The start up drift between 5 minutes and 1 hour after switching on the instrument was 0.129 % at 10 % input and 0.145 % at 90 % input.
- At an open input the current output increased after 0.5 s to the "Fail safe" value of 21.2 mA. At the HHT the failure messages "NaN", followed by "Input open", or "Input open" only were presented.
At short circuited input terminals the current output was equal to a temperature of 24.847 °C. The digital indication at that time was equal to 24.847 °C.
- A line resistance variation of 1000 Ω (200 Ω in the Fe-line and 800 Ω in the CuNi-line) caused a zero shift of 0.108 % and a span shift of -0.013 %.
- Earthing the input caused no zero shift and no span shift.
- The settling time of the output (99 %) after power supply interruptions varying from 20 ms to 500 ms was ≤ 2.5 s. The first three seconds the digital reading on the hand held terminal showed the value of 0.000 °C. After that, a normal temperature reading was shown.
- Apart from the effect as given in the above paragraph about settling time, power supply depressions from 24 Vdc to 18 V d.c. (load 250 Ω, output 100 %) had no effect on the output. From 18 Vdc down to 0 Vdc (500 ms) the output showed transients from 95% to 0 %. The maximum settling time after the test was 2.5 s.
- After the depressions, the hand held terminal often showed the digital temperature failure message "NaN". In that case, the output current was equal to the "fail safe" value of 21.2 mA.

- Over ranging the input to 1 V for a period of 1 minute, followed by a recovery time of 5 minutes caused a remaining zero shift of -0.023% and a remaining span shift of 0.014% .
- The following results of the step response time (τ_{99}) for input steps between 45% and 55% and between 10% and 90% were measured:

step response time (τ_{99}), in s				
	45 % - 55 %	55 % - 45 %	10% - 90 %	90 % - 10 %
Analog	1.8	1.4	1.4	1.8
Digital	5.0	6.0	5.5	5.5

- Connecting the HHT to the terminals of the transmitter caused a zero shift of 0% and a span change of 0% .
- The minimum required load resistance in the two wire output/supply circuit for operation of the HHT was $250\ \Omega$.

2.1.2 RTD transmitter

Test results which were within the manufacturers specification

- During the accuracy test the following errors were found:

Input range	Type of indication	Average error %	Hysteresis %	Repeatability %	Specification including linearity and repeatability %
0 °C to 20 °C	Analog measurement	-0.362	0.194	0.498	± 0.775
0 °C to 100 °C		-0.113	0.040	0.090	± 0.175
-200 °C to + 850 °C		-0.022	0.005	0.011	± 0.049

Input range	Type of indication	Average error %	Hysteresis %	Repeatability %	Specification including linearity and repeatability %
0 °C to 20 °C	Digital indication on hand held terminal, in °C	-0.387	0.169	0.255	0.750
0 °C to 100 °C		-0.095	0.032	0.066	0.150
-200 °C to + 850 °C		-0.019	0.009	0.008	0.024

The resolution of the current output was $0.1\ \mu\text{A}$.

- During the ambient temperature test with two temperature cycles ranging from -40 °C to + 85 °C the following shifts were found:

	mA output		digital indication	
	Zero shift %	Span shift %	Zero shift %	Span shift %
Maximum shift at + 85 °C	-1.326	-3.367	-2.940	-3.255
Maximum shift at -40 °C	-0.953	0.825	0.680	0.890
Remaining shift after the test	0.555	0.602	0.590	0.595

Tests for which effects were not specified

- During the long term drift test for 30 days at a steady input of 90% the maximum shift of the digital output (HHT) was 0 %.
- During the long term drift test for 30 days at a steady input of 90% the maximum shift of the current output (HHT) was 0 %.
- At an open input the current output increased after 0.5 s to the "Fail safe" value of 21.2 mA. At the HHT the failure messages "NaN" and "Input open", or "Input open" only were presented. At short circuited input terminals the current output was 21.2 mA, while the hand held terminal showed the failure messages "NaN" and "Input open", or "Input open" only. Shorting the terminals 1 and 2 and shorting the terminals 3 and 4 showed no effect.
- A line resistance variation of 50 Ω in each input line caused no zero shift and no span shift.

2.2 Comments on construction and use

The transmitter was shipped in a box, together with two mounting screws. A manual in English was also submitted.

A communication unit, also called "hand held terminal", may be connected to the transmitters, thus communicating with the transmitter by means of the HART protocol. In this case the minimum resistance in the current loop must be 250 Ω.

Additional parts, like metal or plastic enclosures, mounting brackets and cable glands may be obtained separately. These parts permit a mounting, remote from the temperature sensor.

2.3 Comments on documentation and identification

Together with the transmitter a manual was supplied in the English language. This manual includes a description of the transmitter, and covers all information about installation, commissioning, troubleshooting, reference data, and HART communication.

In this manual no accuracy specifications are described. After starting the investigation Honeywell has supplied a product sheet with accuracy figures.

The only information on the transmitters was a sticker with the serial number.

On our request the manufacturer has provided us with a copy of the in-house EMC-test results and the CE conformity statement.

2.4 Manufacturer's comments

The manufacturer has no formal comments to the report.

3 TEST RESULTS

Unless otherwise stated the measurements were carried out under the following reference conditions:

Ambient temperature	:	20 °C ± 2 °C
Relative humidity	:	65 % ± 15 %
Power supply voltage	:	24 Vdc ± 0.5 Vdc
Range	:	0 °C - 50 °C (Thermocouple input type J) 0 °C - 20 °C (4 wire RTD input type Pt100)
Current output	:	4 mA - 20 mA
Output load	:	500 Ω
Configurable parameters	:	Damping: 5 s
Others	:	factory default

3.1 Results' summary

3.1.1 Thermocouple transmitter (including output block test)

Unless otherwise stated all measurements were performed with the instrument adjusted to a measuring range of 0 °C to 50 °C (0 μV to 2585 μV) for a type J thermocouple (Fe - CuNi).

Uncertainty estimation thermocouple transmitter measurement

For all ranges, the worst case estimated rms uncertainty of the measurements was:

Digital output: 0.030 % of reading ± 7 mK.

Analog output: 0.030 % of reading ± 7 mK.

Unless otherwise stated all errors are quoted as a percentage of span.

Test number and subject	Measured and observed %	Manufacturers specifications (\pm %) / Report ref.
6.1.3.1 Accuracy TC input, current output <i>Measuring range 0 .. 40 °C</i> - Max. average error - Max. hysteresis - Repeatability - Resolution	-1.261 0.135 0.189 0.001	Refer to graph 1.1 ± 2.025
6.1.3.1 Accuracy TC input, current output <i>Measuring range 0 .. 500 °C</i> - Max. average error - Max. hysteresis - Repeatability - Resolution	-0.139 0.014 0.055 0.001	Refer to graph 1.2 ± 0.185
6.1.3.1 Accuracy TC input, current output <i>Measuring range -180 .. 760 °C</i> - Max. average error - Max. hysteresis - Repeatability - Resolution	-0.056 0.016 0.043 0.001	Refer to graph 1.3 ± 0.153
6.1.3.1 Accuracy TC input, digital output <i>Measuring range 0 .. 40 °C</i> - Max. average error - Max. hysteresis - Repeatability - Resolution	-1.291 0.185 0.272 0.0025	Refer to graph 1.1 ± 2.000
6.1.3.1 Accuracy TC input, digital output <i>Measuring range 0 .. 500 °C</i> - Max. average error - Max. hysteresis - Repeatability - Resolution	-0.099 0.009 0.046 0.001	Refer to graph 1.2 ± 0.160
6.1.3.1 Accuracy TC input, digital output <i>Measuring range -180 .. 760 °C</i> - Max. average error - Max. hysteresis - Repeatability - Resolution	-0.039 0.017 0.084 0.001	Refer to graph 1.3 ± 0.128
6.1.3.1 Output block - Max. average error - Max. hysteresis - Repeatability - Resolution	0.105 % of reading (at 4 mA) 0.036 % of reading (at 4 mA) 0.112 % of reading (at 4 mA) 0.001 mA	

Test number and subject	Measured and observed %	Manufacturers specifications (\pm %) / Report ref.
6.1.3.2 Dead band <i>Measuring range 0 .. 50 °C</i> TC input, current output	<u>10 % input</u> 0.024 <u>90 % input</u> 0.024	
6.1.3.2 Dead band <i>Measuring range 0 .. 500 °C</i> TC input, current output	<u>10 % input</u> 0.024 <u>90 % input</u> 0.024	
6.1.3.2 Dead band <i>Measuring range -180 .. 760 °C</i> TC input, current output	<u>10 % input</u> 0.024 <u>90 % input</u> 0.024	
6.1.3.2 Dead band <i>Measuring range 0 .. 50 °</i> TC input, digital output	<u>10 % input</u> <u>90 % input</u> Better than 0.033	
6.1.3.2 Dead band <i>Measuring range 0 .. 500 °C</i> TC input, digital output	<u>10 % input</u> <u>90 % input</u> Better than 0.003	
6.1.3.2 Dead band <i>Measuring range -180 .. 760 °C</i> TC input, digital output	<u>10 % input</u> <u>90 % input</u> Better than 0.002	
6.1.3.3 Open or short circuited input Open input Short circuited input	Digital reading: Either message "NaN" followed by "Input open" or message "Input open". Analog value 21.2mA Digital reading: 24.847 °C Analog value = 24.847 °C	Analog value = either 3.8 mA or 21.8 mA. Analog value = either 3.8 mA or 21.8 mA.
6.1.3.4 Line resistance 200 Ω in series with the Fe-line and 800 Ω in the CuNi-line	<u>Zero shift</u> 0.108 <u>Span shift</u> -0.013	
6.1.3.5 Output load variations Supply voltage at terminals: 35 Vdc Load from 250 Ω to 1110 Ω Load is 250 Ω Load is 1110 Ω Message when load < 100 Ω Message when load < 250 Ω and load > 100 Ω .	Shift with respect to reference values at a load of 500 Ω <u>Zero shift</u> <u>Span shift</u> 0.080 -0.222 0.023 -0.253 No device found Communication error	Load resistance 0 ... 1110 ohm.

Test number and subject	Measured and observed %	Manufacturers specifications (\pm %) / Report ref.												
6.1.3.6 Series mode interference Shift at 50 % of span. Influence on output signal	<table> <tr> <td>U ac (mV)</td> <td>Shift</td> </tr> <tr> <td>5</td> <td>-0.18</td> </tr> <tr> <td>6</td> <td>-2.430</td> </tr> <tr> <td>10</td> <td>-2.351</td> </tr> <tr> <td>35</td> <td>-2.205</td> </tr> <tr> <td>> 35</td> <td>> 20</td> </tr> </table> No 50 Hz signal was detected.	U ac (mV)	Shift	5	-0.18	6	-2.430	10	-2.351	35	-2.205	> 35	> 20	
U ac (mV)	Shift													
5	-0.18													
6	-2.430													
10	-2.351													
35	-2.205													
> 35	> 20													
6.1.3.7 Common mode	Omitted	See chapter 6.1.2												
6.2.1.8 Power supply variation Load = 250 Ω Supply from 10.8 V to 35.0 V Effect on the zero or span Power supply voltage = 10.8 Vdc Power supply voltage = 35.0 Vdc	Shift with respect to reference values at a power supply voltage of 24 Vdc. <table> <tr> <td><u>Zero shift</u></td> <td><u>Span shift</u></td> </tr> <tr> <td>0.056</td> <td>0.126</td> </tr> <tr> <td>-0.124</td> <td>0.004</td> </tr> </table>	<u>Zero shift</u>	<u>Span shift</u>	0.056	0.126	-0.124	0.004	10.8 Vdc .. 35.0 Vdc at terminals.						
<u>Zero shift</u>	<u>Span shift</u>													
0.056	0.126													
-0.124	0.004													
6.1.3.9 Power supply interruptions Supply : 24 V Load : 250 Ω Output : 100 % Analog Digital	Dip to 0 mA for a period of 1.6 s including the interruption time of 0.5 s. 1.8 s after the return of the power supply voltage the output value was within 1 % of the nominal value. Value 0.000 °C for three seconds., followed by indication of normal temperature.	1 s To reach 63% of final value with 0 s damping.												
6.1.3.10 Power supply depression Supply : 24 V Load : 250 Ω Output : 100 % Interruption: 5 ms 10 ms 100 ms 500 ms	Dip to 0 Vdc; analog results <table> <tr> <td><u>Transient</u></td> <td><u>Settling time</u></td> </tr> <tr> <td>Dip to 14.6 mA</td> <td>2.0 s</td> </tr> <tr> <td>Dip to 14.6 mA</td> <td>2.0 s</td> </tr> <tr> <td>Dip to 14.0 mA</td> <td>2.2 s</td> </tr> <tr> <td>Dip to 0 mA</td> <td>2.5 s</td> </tr> </table>	<u>Transient</u>	<u>Settling time</u>	Dip to 14.6 mA	2.0 s	Dip to 14.6 mA	2.0 s	Dip to 14.0 mA	2.2 s	Dip to 0 mA	2.5 s			
<u>Transient</u>	<u>Settling time</u>													
Dip to 14.6 mA	2.0 s													
Dip to 14.6 mA	2.0 s													
Dip to 14.0 mA	2.2 s													
Dip to 0 mA	2.5 s													
Interruption: 5 ms 10 ms 100 ms 500 ms	Dip to 12 Vdc; analog results Dip to 14.6 mA 2.0 s Dip to 14.6 mA 2.0 s Dip to 14.6 mA 2.0 s Dip to 12.6 mA 2.5 s													

Test number and subject	Measured and observed %	Manufacturers specifications (\pm %) / Report ref.
<p>Interruption: 500 ms Dip to 17 Vdc for 500 ms</p> <p>Interruption: 5 ms, 10 ms, 50 ms, 100ms, 500 ms</p> <p>Interruption: 5 ms,</p> <p>Interruption: 5 ms, 10 ms, 50 ms, 100ms, 500 ms</p> <p>Interruption: 5 ms, 10 ms, 50 ms, 100ms, 500 ms</p>	<p>Dip to 16 Vdc; analog results Dip to 14.6 mA 2.0 s No effect</p> <p><u>Transient</u> <u>Settling time</u> Dip to any value between 18 Vdc and 24 Vdc; digital results No effect.</p> <p>Dip to any value lower than 18 Vdc; except for 0 V; digital results No effect.</p> <p>Digital failure message "NaN", followed by "Hardware failure". Restart after power down and up. Dip to 0 V; digital results A temperature of 0.000 °C and a current of 4.000 mA is presented for a period of 3 seconds. This is followed by presentation of the normal temperature.</p>	
<p>6.1.3.11 Earthing the input or output terminals</p> <p>Input "+" terminal Input "-" terminal Output "+" terminal Output "-" terminal</p>	<p><u>Zero shift</u> <u>Span shift</u></p> <p>no shift no shift no shift no shift no shift no shift no shift no shift</p>	
<p>6.1.3.12 Ambient temperature 2 Cycles between +85 °C and -40 °C <i>TC input, current output</i></p> <p>at +20 °C (1) at +40 °C at +60 °C at +85 °C at +20 °C (2) at 0 °C at -20 °C at -40 °C at +20 °C (3) at +40 °C at +60 °C at +85 °C at +20 °C (4) at 0 °C at -20 °C at -40 °C at +20 °C (5)</p>	<p><u>Zero shift</u> <u>Span shift</u></p> <p>0.000 0.000 -0.695 -0.530 -0.645 -0.436 -0.661 -0.399 0.277 0.435 0.535 -0.316 1.321 1.239 1.645 1.584 -0.012 0.086 -0.552 -0.299 -0.597 -0.392 -0.460 -0.238 0.539 0.562 0.821 0.809 1.290 1.218 1.681 1.504 0.130 0.233</p>	<p>-40 °C.. +85 °C</p> <p>Refer to graphs 1.4 and 1.5</p> <p><u>Zero shift(\pm)</u> <u>Span shift(\pm)</u></p> <p>0.000 0.000 1.330 1.442 3.230 3.502 5.605 6.077 0.000 0.000 1.900 2.060 3.800 4.120 5.700 6.180 0.000 0.000 1.330 1.442 3.230 3.502 5.605 6.077 0.000 0.000 1.900 2.060 3.800 4.120 5.700 6.180 0.000 0.000</p>

Test number and subject	Measured and observed %		Manufacturers specifications (± %) / Report ref.	
<i>TC input, digital output</i>	<u>Zero shift</u>	<u>Span shift</u>	<u>Zero shift (±)</u>	<u>Span shift (±)</u>
at + 20 °C (1)	0.000	0.000	0.000	0.000
at + 40 °C	-0.631	-0.567	0.700	0.812
at + 60 °C	-0.622	-0.441	1.700	1.972
at + 85 °C	-0.667	-0.377	2.950	3.422
at + 20 °C (2)	0.189	0.376	0.000	0.000
at 0 °C	0.598	0.618	1.000	1.160
at -20 °C	1.344	1.193	2.000	2.320
at -40 °C	1.647	1.660	3.000	3.480
at + 20 °C (3)	0.018	0.044	0.000	0.000
at + 40 °C	-0.543	-0.381	0.700	0.812
at + 60 °C	-0.543	-0.410	1.700	1.972
at + 85 °C	-0.335	-0.256	2.950	3.422
at + 20 °C (4)	0.527	0.536	0.000	0.000
at 0 °C	0.877	0.780	1.000	1.160
at -20 °C	1.364	1.185	2.000	2.320
at -40 °C	1.689	1.547	3.000	3.480
at + 20 °C (5)	0.005	0.273	0.000	0.000
6.1.3.13 Humidity			0 % .. 100 %	
During last 4 hours at 40 °C	<u>Zero shift</u>	<u>Span shift</u>		
After recovery, at standard conditions	-0.543	-0.381		
	0.296	0.572		
6.1.3.14 Vibration	Omitted		See chapter 6.1.2	
6.1.3.15 Start-up drift	Analog			
	<u>10% input</u>	<u>90% input</u>		
Shift after 5 minutes	-0.142	0.130		
Shift after 1 hour	0.336	0.744		
	Digital			
	<u>10% input</u>	<u>90% input</u>		
Shift after 5 minutes	-0.136	0.108		
Shift after 1 hour	0.288	0.644		
6.1.3.16 Long term drift	30 days at a steady input of 90%		Refer to graph 1.6	
	0.046			
6.1.3.17 Ripple content of output	AC-component on the output			
At 10 % output	0.0005			
At 50 % output	0.0005			
At 90% output	0.0005			
6.1.3.18 Over ranging	1V, for 1 minute to the input			
Shift after 5 minutes recovery	<u>Zero shift</u>	<u>Span shift</u>		
	-0.023	0.014		
	Digital reading during the over ranging: "NaN"			
6.1.3.19 Step response time (99)	Input step			
	<u>45% - 55%</u>	<u>55% - 45%</u>		
Analog reading	1.8 s	1.4 s		
Digital reading	5.0 s	5.0 s		
	<u>10% - 90%</u>	<u>90% - 10%</u>		
Analog reading	1.4 s	1.8 s		
Digital reading	5.5 s	5.5 s		

Test number and subject	Measured and observed %	Manufacturers specifications (\pm %) / Report ref.
6.1.3.20 Supply reversal Effect during reversal Remaining effect	Analog: Output current = 0 mA Digital reading: "Device disconnected" None	
EMC tests 6.1.3.21 Fast transients 6.1.3.22 Magnetic field interference 6.1.3.23 Electro static discharge 6.1.3.24 Radiated immunity	All EMC test results have been omitted	
Constructional aspects	No remarks	See also chapter 2.2

3.1.2 RTD transmitter

Unless otherwise stated all measurements were performed with the instrument adjusted to a measuring range of 0 °C to 20 °C (0 Ω to 107.79 Ω) for a type Pt100 to DIN/IEC 751.

Uncertainty estimation RTD transmitter measurements

The estimated worst case rms uncertainty of the measurements was:

Minimum measuring range 0 °C to 20 °C (accuracy measurements and most other measurements):

Digital output: 0.004 % of reading ± 1 mK; mA output: 0.005 % of reading.

Range 0 °C to 100 °C (accuracy measurements only):

Digital output: 0.004 % of reading ± 1 mK; mA output: 0.005 % of reading.

Measuring range -200 °C to 850 °C (accuracy measurements only):

Digital output: 0.006 % of reading ± 1 mK; mA output: 0.006 % of reading.

Unless otherwise stated all errors are quoted as a percentage of span.

Test number and subject	Measured and observed %	Manufacturer s specifications (± %) / Report ref.
6.1.3.1 Accuracy Pt100 input, current output <i>Measuring range 0 .. 20 °C</i> - Max. average error - Max. hysteresis - Repeatability - Resolution	-0.362 0.194 0.498 0.001	Refer to graph 2.1 0.775
6.1.3.1 Accuracy Pt 100 input, current output <i>Measuring range 0 .. 100 °C</i> - Max. average error - Max. hysteresis - Repeatability - Resolution	-0.113 0.040 0.090 0.001	Refer to graph 2.2 0.175
6.1.3.1 Accuracy Pt100 input, current output <i>Measuring range -200 °C to + 850 °C</i> - Max. average error - Max. hysteresis - Repeatability - Resolution	-0.022 0.005 0.011 0.001	Refer to graph 2.3 0.049
6.1.3.1 Accuracy Pt100 input, digital output <i>Measuring range 0 .. 20 °C</i> - Max. average error - Max. hysteresis - Repeatability - Resolution	-0.387 0.169 0.255 0.001	Refer to graph 2.1 0.750

Test number and subject	Measured and observed %	Manufacturer s specifications (± %) / Report ref.
6.1.3.1 Accuracy Pt input, digital output <i>Measuring range 0 .. 100 °C</i> - Max. average error - Max. hysteresis - Repeatability - Resolution	-0.095 0.032 0.066 0.01	Refer to graph 2.2 0.150
6.1.3.1 Accuracy Pt input, digital output <i>Measuring range -200 .. 850 °C</i> - Max. average error - Max. hysteresis - Repeatability - Resolution	-0.019 0.009 0.008 0.05	Refer to graph 2.3 0.024
6.1.3.2 Dead band <i>Measuring range 0 .. 20 °C</i> Pt input, current output	<u>10 % input</u> <u>90 % input</u> 0.024 0.024	
6.1.3.2 Dead band <i>Measuring range 0 .. 100 °C</i> Pt input, current output	<u>10 % input</u> <u>90 % input</u> 0.024 0.024	
6.1.3.2 Dead band <i>Measuring range -200 .. 850 °C</i> Pt input, current output	<u>10 % input</u> <u>90 % input</u> 0.024 0.024	
6.1.3.2 Dead band <i>Measuring range 0 .. 20 °C</i> Pt input, digital output	<u>10 % input</u> <u>90 % input</u> 0.080 0.080	
6.1.3.2 Dead band <i>Measuring range 0 .. 100 °C</i> Pt input, digital output	<u>10 % input</u> <u>90 % input</u> 0.016 0.016	
6.1.3.2 Dead band <i>Measuring range -200 .. 850 °C</i> Pt input, digital output	<u>10 % input</u> <u>90 % input</u> 0.002 0.002	
6.1.3.3 Open or short circuited input Input 1 open Input 1 and 2 open Input 1 and 2 and 3 open Input 1 and 2 and 3 and 4 open Input 1 and 2 and 4 open Input 1 and 3 open Input 1 and 3 and 4 open	Digital indication: "Input open" Analog current: 21.2 mA Digital indication: "NaN", followed by "Input open" Analog current: 21.2 mA Digital indication: "NaN", followed by "Input open" Analog current: 21.2 mA Digital indication: "NaN", followed by "Input open" Analog current: 21.2 mA Digital indication: "NaN", followed by "Input open" Analog current: 21.2 mA Digital indication: "NaN", followed by "Input open" Analog current: 21.2. Digital indication: "NaN", followed by "Input open" Analog current: 21.2 mA	Analog current: 3.8 mA or 21.3 mA Analog current: 3.8 mA or 21.3 mA Analog current: 3.8 mA or 21.3 mA Analog current: 3.8 mA or 21.3 mA Analog current: 3.8 mA or 21.3 mA Analog current: 3.8 mA or 21.3 mA Analog current: 3.8 mA or 21.3 mA

Test number and subject	Measured and observed %	Manufacturer s specifications (± %) / Report ref.																																																																								
6.1.3.11 Ambient temperature 2 Cycles between + 85 °C and -40 °C <i>Pt100 input, current output</i>	<table border="1"> <thead> <tr> <th><u>Zero shift</u></th> <th><u>Span shift</u></th> </tr> </thead> <tbody> <tr><td>at + 20 °C (1)</td><td>0.000</td></tr> <tr><td>at + 40 °C</td><td>-0.645</td></tr> <tr><td>at + 60 °C</td><td>-1.277</td></tr> <tr><td>at + 85 °C</td><td>-1.280</td></tr> <tr><td>at + 20 °C (2)</td><td>0.854</td></tr> <tr><td>at 0 °C</td><td>1.149</td></tr> <tr><td>at -20 °C</td><td>1.144</td></tr> <tr><td>at -40 °C</td><td>0.484</td></tr> <tr><td>at + 20 °C (3)</td><td>-0.045</td></tr> <tr><td>at + 40 °C</td><td>-0.897</td></tr> <tr><td>at + 60 °C</td><td>-1.275</td></tr> <tr><td>at + 85 °C</td><td>-1.326</td></tr> <tr><td>at + 20 °C (4)</td><td>0.853</td></tr> <tr><td>at 0 °C</td><td>1.148</td></tr> <tr><td>at -20 °C</td><td>1.260</td></tr> <tr><td>at -40 °C</td><td>0.953</td></tr> <tr><td>at + 20 °C (5)</td><td>0.555</td></tr> </tbody> </table>	<u>Zero shift</u>	<u>Span shift</u>	at + 20 °C (1)	0.000	at + 40 °C	-0.645	at + 60 °C	-1.277	at + 85 °C	-1.280	at + 20 °C (2)	0.854	at 0 °C	1.149	at -20 °C	1.144	at -40 °C	0.484	at + 20 °C (3)	-0.045	at + 40 °C	-0.897	at + 60 °C	-1.275	at + 85 °C	-1.326	at + 20 °C (4)	0.853	at 0 °C	1.148	at -20 °C	1.260	at -40 °C	0.953	at + 20 °C (5)	0.555	-40 .. + 85 °C Refer to graph 2.4 <table border="1"> <thead> <tr> <th><u>Zero shift (±)</u></th> <th><u>Span shift (±)</u></th> </tr> </thead> <tbody> <tr><td>0.000</td><td>0.000</td></tr> <tr><td>2.484</td><td>2.555</td></tr> <tr><td>6.033</td><td>6.205</td></tr> <tr><td>10.469</td><td>10.768</td></tr> <tr><td>0.000</td><td>0.000</td></tr> <tr><td>3.549</td><td>3.650</td></tr> <tr><td>7.098</td><td>7.300</td></tr> <tr><td>10.647</td><td>10.950</td></tr> <tr><td>0.000</td><td>0.000</td></tr> <tr><td>2.484</td><td>2.555</td></tr> <tr><td>6.033</td><td>6.205</td></tr> <tr><td>10.469</td><td>10.768</td></tr> <tr><td>0.000</td><td>0.000</td></tr> <tr><td>3.549</td><td>3.650</td></tr> <tr><td>7.098</td><td>7.300</td></tr> <tr><td>10.674</td><td>10.950</td></tr> <tr><td>0.000</td><td>0.000</td></tr> </tbody> </table>	<u>Zero shift (±)</u>	<u>Span shift (±)</u>	0.000	0.000	2.484	2.555	6.033	6.205	10.469	10.768	0.000	0.000	3.549	3.650	7.098	7.300	10.647	10.950	0.000	0.000	2.484	2.555	6.033	6.205	10.469	10.768	0.000	0.000	3.549	3.650	7.098	7.300	10.674	10.950	0.000	0.000
<u>Zero shift</u>	<u>Span shift</u>																																																																									
at + 20 °C (1)	0.000																																																																									
at + 40 °C	-0.645																																																																									
at + 60 °C	-1.277																																																																									
at + 85 °C	-1.280																																																																									
at + 20 °C (2)	0.854																																																																									
at 0 °C	1.149																																																																									
at -20 °C	1.144																																																																									
at -40 °C	0.484																																																																									
at + 20 °C (3)	-0.045																																																																									
at + 40 °C	-0.897																																																																									
at + 60 °C	-1.275																																																																									
at + 85 °C	-1.326																																																																									
at + 20 °C (4)	0.853																																																																									
at 0 °C	1.148																																																																									
at -20 °C	1.260																																																																									
at -40 °C	0.953																																																																									
at + 20 °C (5)	0.555																																																																									
<u>Zero shift (±)</u>	<u>Span shift (±)</u>																																																																									
0.000	0.000																																																																									
2.484	2.555																																																																									
6.033	6.205																																																																									
10.469	10.768																																																																									
0.000	0.000																																																																									
3.549	3.650																																																																									
7.098	7.300																																																																									
10.647	10.950																																																																									
0.000	0.000																																																																									
2.484	2.555																																																																									
6.033	6.205																																																																									
10.469	10.768																																																																									
0.000	0.000																																																																									
3.549	3.650																																																																									
7.098	7.300																																																																									
10.674	10.950																																																																									
0.000	0.000																																																																									
<i>Pt100 input, digital output</i>	<table border="1"> <thead> <tr> <th><u>Zero shift</u></th> <th><u>Span shift</u></th> </tr> </thead> <tbody> <tr><td>at + 20 °C (1)</td><td>0.000</td></tr> <tr><td>at + 40 °C</td><td>-0.585</td></tr> <tr><td>at + 60 °C</td><td>-1.765</td></tr> <tr><td>at + 85 °C</td><td>-2.940</td></tr> <tr><td>at + 20 °C (2)</td><td>0.885</td></tr> <tr><td>at 0 °C</td><td>1.680</td></tr> <tr><td>at -20 °C</td><td>1.180</td></tr> <tr><td>at -40 °C</td><td>0.680</td></tr> <tr><td>at + 20 °C (3)</td><td>0.000</td></tr> <tr><td>at + 40 °C</td><td>-0.880</td></tr> <tr><td>at + 60 °C</td><td>-1.765</td></tr> <tr><td>at + 85 °C</td><td>-2.940</td></tr> <tr><td>at + 20 °C (4)</td><td>0.885</td></tr> <tr><td>at 0 °C</td><td>1.180</td></tr> <tr><td>at -20 °C</td><td>1.180</td></tr> <tr><td>at -40 °C</td><td>0.590</td></tr> <tr><td>at + 20 °C (5)</td><td>0.590</td></tr> </tbody> </table>	<u>Zero shift</u>	<u>Span shift</u>	at + 20 °C (1)	0.000	at + 40 °C	-0.585	at + 60 °C	-1.765	at + 85 °C	-2.940	at + 20 °C (2)	0.885	at 0 °C	1.680	at -20 °C	1.180	at -40 °C	0.680	at + 20 °C (3)	0.000	at + 40 °C	-0.880	at + 60 °C	-1.765	at + 85 °C	-2.940	at + 20 °C (4)	0.885	at 0 °C	1.180	at -20 °C	1.180	at -40 °C	0.590	at + 20 °C (5)	0.590	Refer to graph 2.5 <table border="1"> <thead> <tr> <th><u>Zero shift (±)</u></th> <th><u>Span shift (±)</u></th> </tr> </thead> <tbody> <tr><td>0.000</td><td>0.000</td></tr> <tr><td>0.909</td><td>0.980</td></tr> <tr><td>2.208</td><td>2.380</td></tr> <tr><td>3.832</td><td>4.130</td></tr> <tr><td>0.000</td><td>0.000</td></tr> <tr><td>1.299</td><td>1.400</td></tr> <tr><td>2.598</td><td>2.800</td></tr> <tr><td>3.897</td><td>4.200</td></tr> <tr><td>0.000</td><td>0.000</td></tr> <tr><td>0.909</td><td>0.980</td></tr> <tr><td>2.208</td><td>2.380</td></tr> <tr><td>3.832</td><td>4.130</td></tr> <tr><td>0.000</td><td>0.000</td></tr> <tr><td>1.299</td><td>1.400</td></tr> <tr><td>2.598</td><td>2.800</td></tr> <tr><td>3.897</td><td>4.200</td></tr> <tr><td>0.000</td><td>0.000</td></tr> </tbody> </table>	<u>Zero shift (±)</u>	<u>Span shift (±)</u>	0.000	0.000	0.909	0.980	2.208	2.380	3.832	4.130	0.000	0.000	1.299	1.400	2.598	2.800	3.897	4.200	0.000	0.000	0.909	0.980	2.208	2.380	3.832	4.130	0.000	0.000	1.299	1.400	2.598	2.800	3.897	4.200	0.000	0.000
<u>Zero shift</u>	<u>Span shift</u>																																																																									
at + 20 °C (1)	0.000																																																																									
at + 40 °C	-0.585																																																																									
at + 60 °C	-1.765																																																																									
at + 85 °C	-2.940																																																																									
at + 20 °C (2)	0.885																																																																									
at 0 °C	1.680																																																																									
at -20 °C	1.180																																																																									
at -40 °C	0.680																																																																									
at + 20 °C (3)	0.000																																																																									
at + 40 °C	-0.880																																																																									
at + 60 °C	-1.765																																																																									
at + 85 °C	-2.940																																																																									
at + 20 °C (4)	0.885																																																																									
at 0 °C	1.180																																																																									
at -20 °C	1.180																																																																									
at -40 °C	0.590																																																																									
at + 20 °C (5)	0.590																																																																									
<u>Zero shift (±)</u>	<u>Span shift (±)</u>																																																																									
0.000	0.000																																																																									
0.909	0.980																																																																									
2.208	2.380																																																																									
3.832	4.130																																																																									
0.000	0.000																																																																									
1.299	1.400																																																																									
2.598	2.800																																																																									
3.897	4.200																																																																									
0.000	0.000																																																																									
0.909	0.980																																																																									
2.208	2.380																																																																									
3.832	4.130																																																																									
0.000	0.000																																																																									
1.299	1.400																																																																									
2.598	2.800																																																																									
3.897	4.200																																																																									
0.000	0.000																																																																									
6.1.3.16 Long term drift 30 days at a steady input of 90%	0.000	Refer to graph 2.6																																																																								
6.1.3.24 Radiated immunity (EMC)	All EMC test results have been omitted.																																																																									
Constructional aspects	No remarks	See also chapter 2.2																																																																								

3.1.3 Graphs

Declaration of the names in the graphs

Graphs 1.1, 1.2, 1.3, 2.1, 2.2, 2.3	
dig_up	absolute error in digital reading, for increasing temperatures
dig_down	absolute error in digital reading, for decreasing temperatures
ana_up	absolute error in output current, for increasing temperatures
ana_down	absolute error in output current, for decreasing temperatures
dig_lim+	maximum allowed positive error in digital reading
dig_lim-	maximum allowed negative error in digital reading
ana_lim+	maximum allowed positive error in output current
ana_lim-	maximum allowed negative error in output current
Graphs 1.4, 1.5, 2.4, 2.5	
zero_error	relative error in digital reading at various environmental temperatures, with respect to the initial measurement, at a reference temperature of 0 °C
span_error	relative error in output current at various environmental temperatures, with respect to the initial measurement, at a reference temperature of 20 °C for the Pt100 application and 50 °C for the thermocouple application
zero_lim+	maximum allowed relative positive error in digital reading, with respect to the initial measurement, at a reference temperature of 0 °C
zero_lim-	maximum allowed relative negative error in digital reading, with respect to the initial measurement, at a reference temperature of 0 °C
span_lim+	maximum allowed relative positive error in output current, with respect to the initial measurement, at a reference temperature of 0 °C
span_lim-	maximum allowed relative negative error in output current, with respect to the initial measurement, at a reference temperature of 0 °C
Graphs 1.6, 2.6	
digital	relative error in digital reading with respect to the initial measurement
analog	relative error in output current with respect to the initial measurement
Graph 3.1	
ana_up	absolute error of the output current, for increasing reference values
ana_down	absolute error of the output current, for decreasing reference values

1.3.1 Thermocouple transmitters

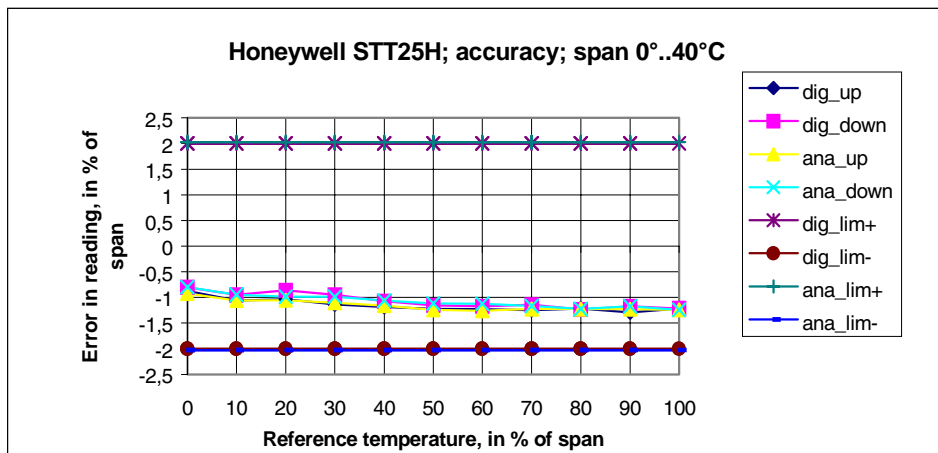

Graph 1.1

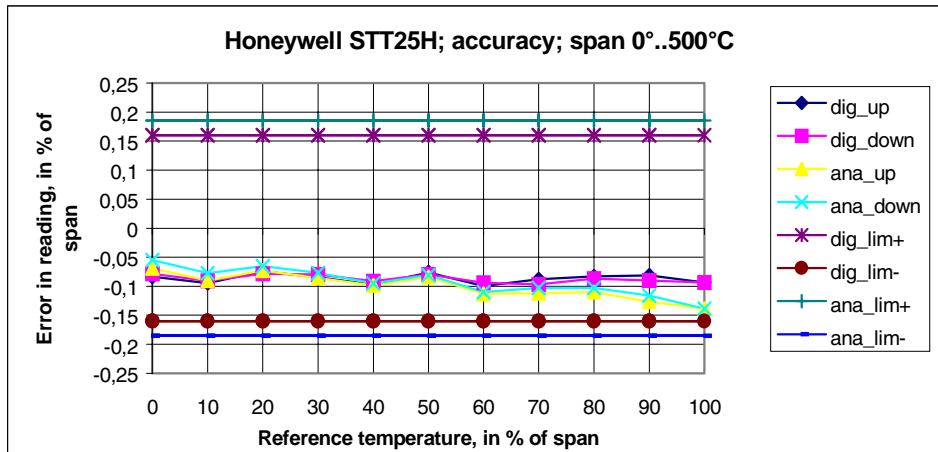

Graph 1.2

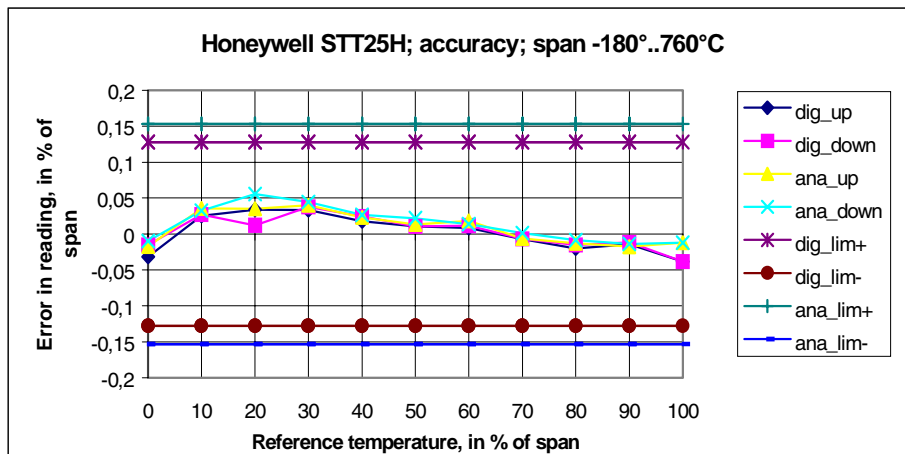

Graph 1.3

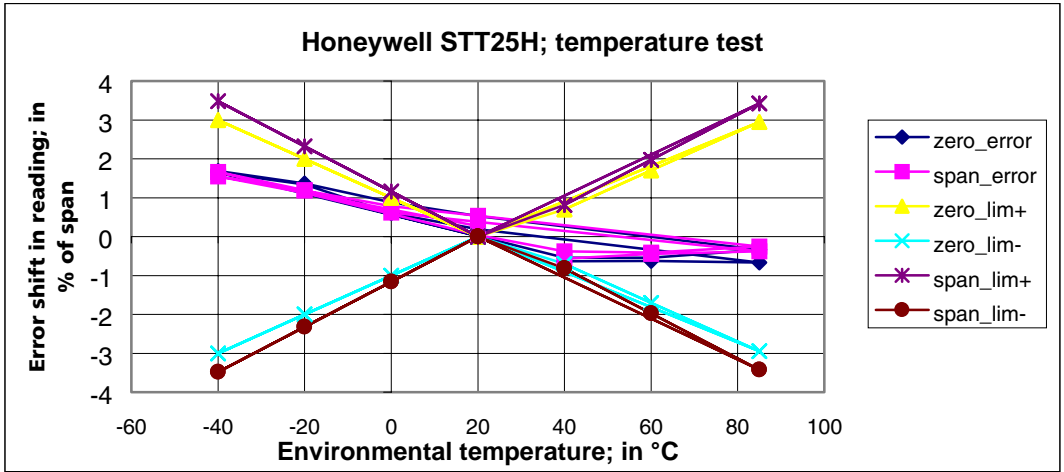

Graph 1.4; digital reading

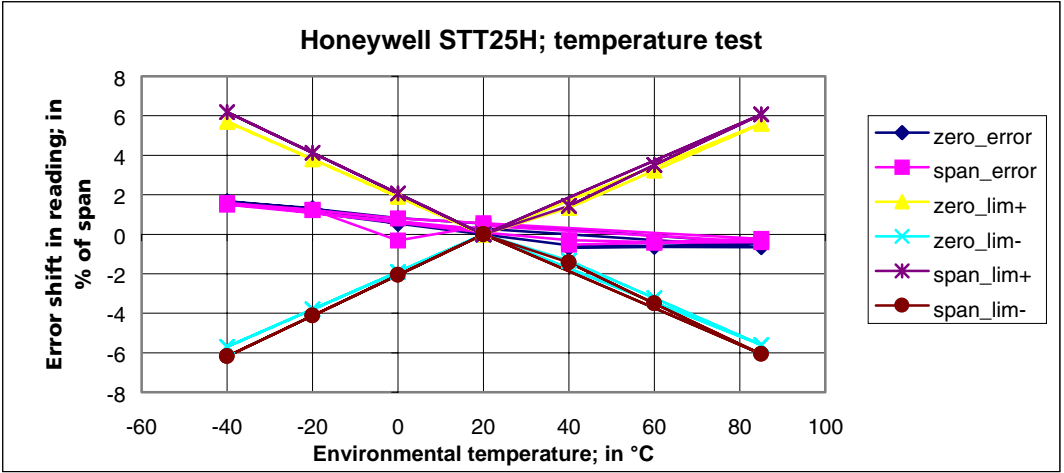

Graph 1.5 analog reading

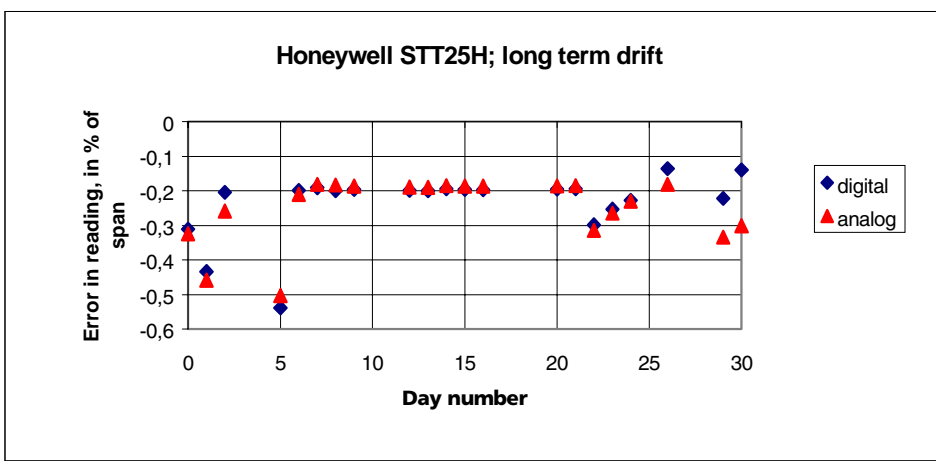

Graph 1.6

1.3.2 RTD transmitter

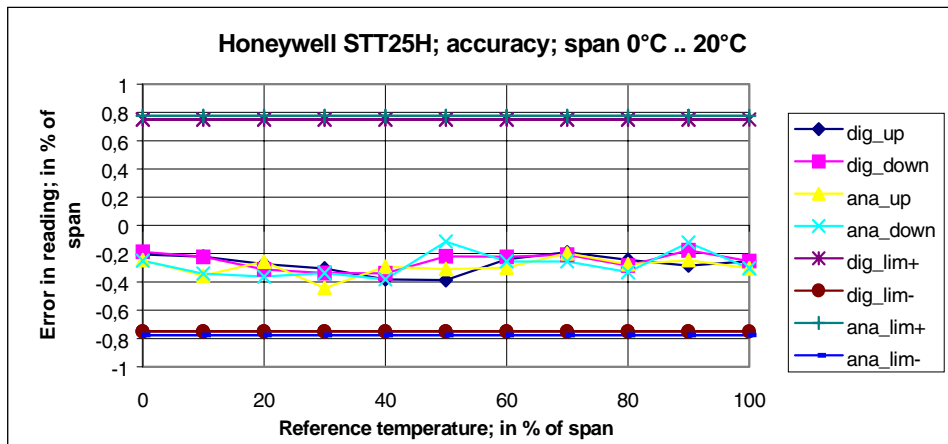

Graph 2.1

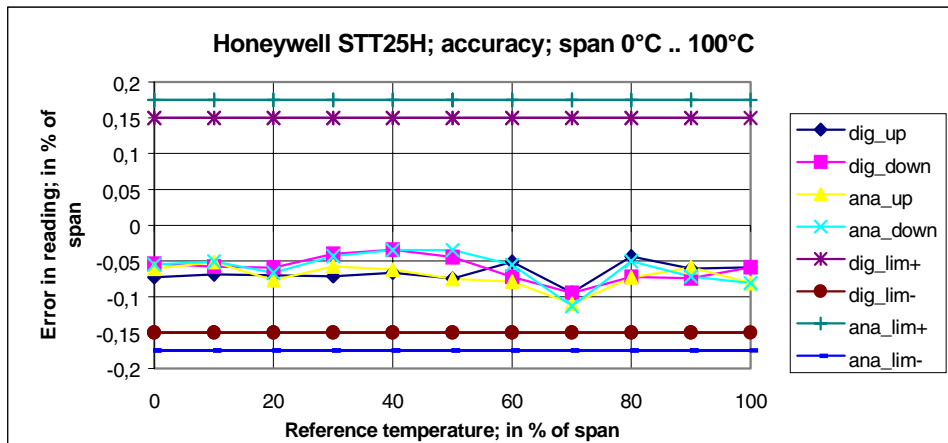

Graph 2.2

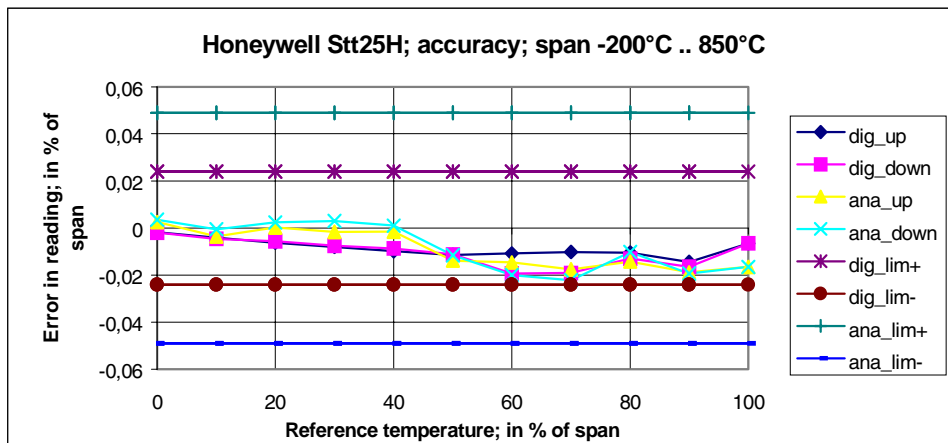

Graph 2.3

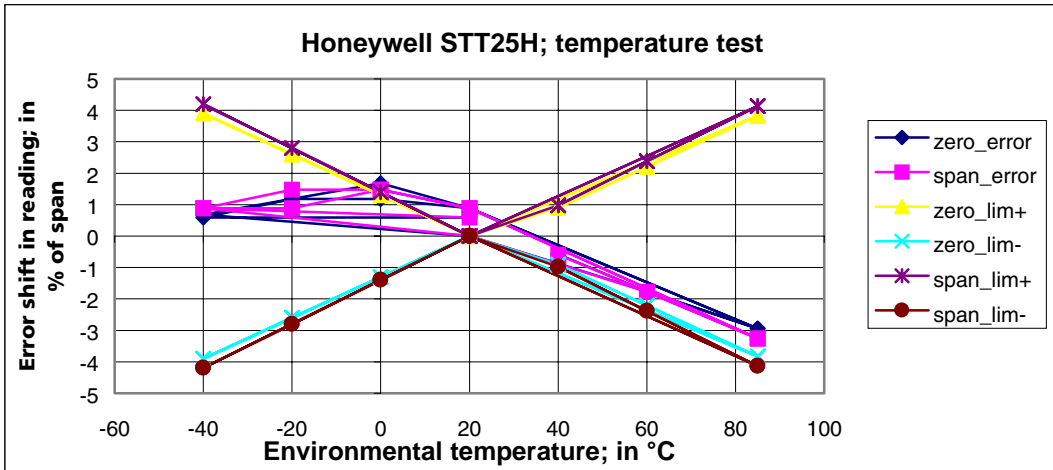

Graph 2.4; digital reading

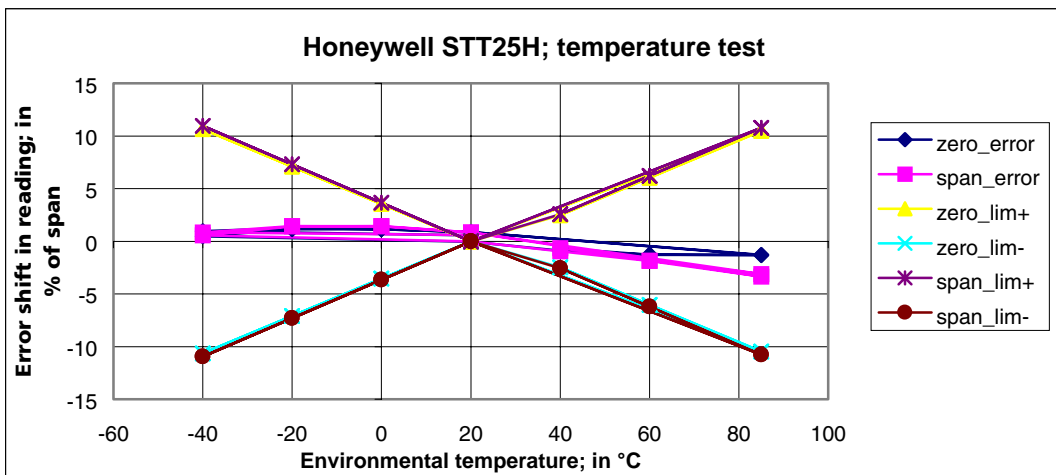

Graph 2.5; analog reading

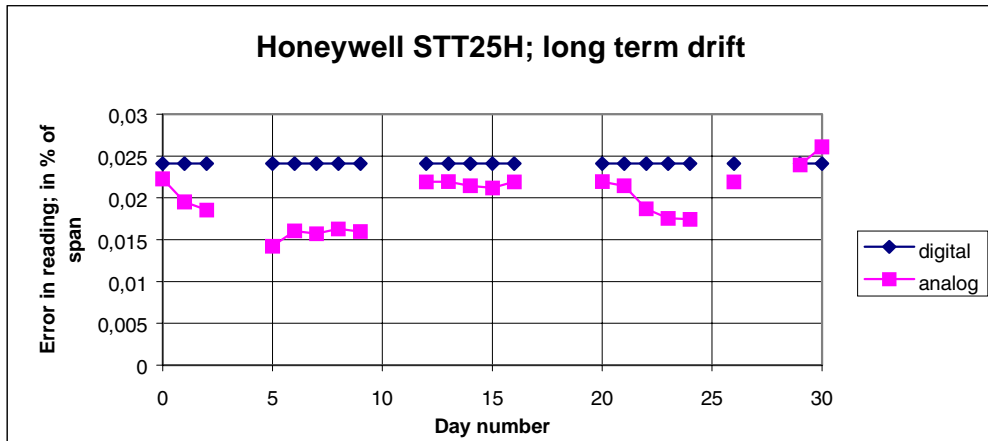

Graph 2.6

3.1.3.3 Output block

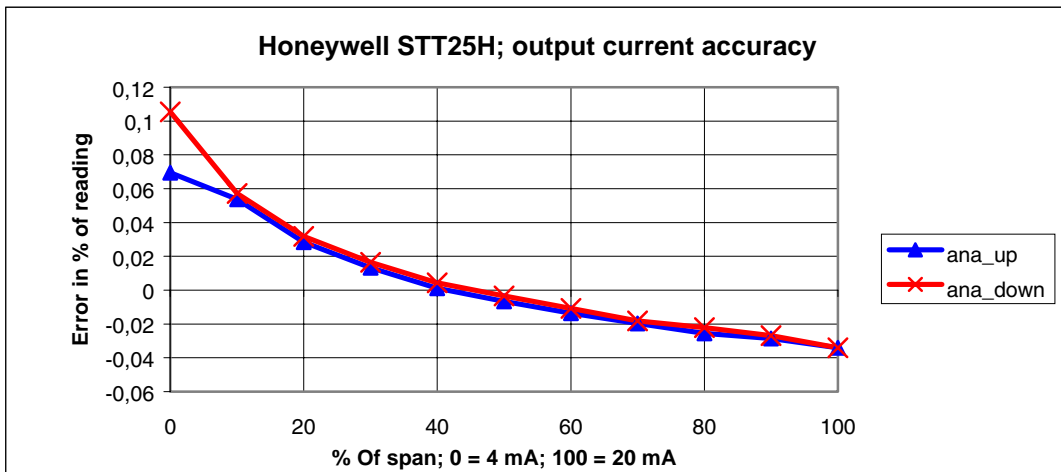

Graph 3.1

4. MANUFACTURERS GENERAL DATA AND SPECIFICATIONS

Instrument specification and other details provided by the manufacturer

Manufacturer : Honeywell S.A.
Zone Industrielle de Longpré
80084 Amiens CEDEX 2
France
Tel. + 33 22 545656
fax. + 33 22 545757

Instrument : SMART temperature transmitter
Model : STT 25H
Serial numbers : 2409 (long term test only)
2429 (temperature test and climate test with the Pt100 configuration)
16000 (accuracy test with Pt100 configuration and with thermocouple configuration for range $-180\text{ }^{\circ}\text{C} \dots 760\text{ }^{\circ}\text{C}$; open/short circuit test; line resistance effect; power supply interruptions and depressions; earthing; start-up drift and over ranging)
2439 (all other tests)

STT 3000 Series STT250 SMART TEMPERATURE TRANSMITTER Models STT25H, STT25M, STT25D

EN01-6031 09/99

PRODUCT SPECIFICATION SHEET

OVERVIEW

Honeywell's STT 3000 family of microprocessor based smart temperature transmitters includes both the Series STT250 described in this specification sheet and the higher performance STT350 described in Product Specification Sheet EN01-5222. The STT350 offers high performance and advanced functionality.

The STT250 units offer competitive performance in a more compact module and with a wider range of smart communications protocols.

Choose the unit to meet your application needs :

- **STT25H** with HART™ communications when this popular protocol is preferred. Configuration of the HART unit can be made with any of the listed HART Communication Foundation tools.
- **STT25M** for 4-20mA operation and local/ remote configuration via Honeywell's digital DE protocol from the Smart Field Communicator (SFC) or Smart Configuration Toolkit PC based software (SCT).
- **STT25D** with digital DE protocol for either 4-20mA operation or digital integration into the TDC 3000™/ TPS 3000™ control system.

All units support the same wide range of primary sensor types, are 2 wire powered and give an output linearised to temperature over the 2 power wires. Leadwire compensation is provided for RTD (Resistance Temperature Detectors) and internal digital cold junction compensation is provided for Thermocouples. MilliVolt and Ohms sensor inputs can also be accepted.

FEATURES

Smart communication protocols available include HART or DE Honeywell.

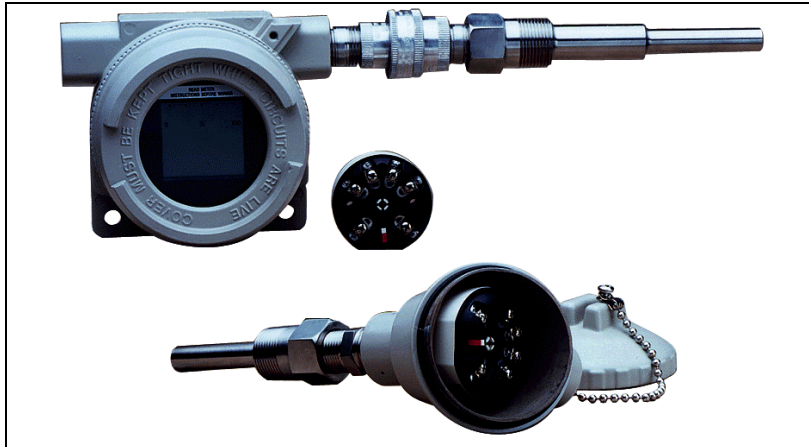

- Direct sensor head mounting in DIN Form A housing. Housing materials available include plastic, aluminium, 316SS and cast iron.
- Mounting options include wall, pipe, DIN rail or direct sensor head mounting with or without a housing.
- Single model accepts input signal from a wide choice of primary sensors to satisfy varying application requirements with minimum transmitter inventory.
- Suitable for 4, 3 or 2 wire Pt100 and Pt200 RTD measurement.
- Hard wired upscale/ downscale failsafe link to ensure secure operation in the event of a failure.
- Open circuit sensor analysis carried out in every measurement cycle.
- Selectable latching/non-latching failsafe operation for open circuit sensor.
- Integral analogue or digital indication meter option.
- Analogue to Digital converter validated frequently.

DESCRIPTION

The STT250 transmitters are suitable as replacements for any conventional or most smart temperature transmitters in use today. The memory contains the characteristics of most commonly used temperature sensors.

You can easily use the hand held communicator or PC tool to configure the transmitter for any of these sensors and it will automatically correct for their associated non-linearities.

Accuracies stated below are available merely by selecting the sensor type and range (i.e. without user calibration). Calibration of the LRV/URV end points will typically give accuracy improvements of 2 times. Sensor errors can be calibrated out by calibration to the specific sensor either by having it at the LRV/URV temperatures or by simulation of the known values.

In addition, all units pass through Environmental Stress Screening by fast cycling between -40°C and +85°C to ensure maximum product reliability. During this process the ambient temperature coefficients are determined for each unit and burned into memory to ensure temperature compensation over a wide range of operating conditions.

Configuration adjustments and diagnostics checks can be made either locally or remotely over the signal wires from anywhere along their route. This enables major savings in manpower time during commissioning, start up and maintenance activities.

Performance Under Rated Conditions

Sensor	Digital Accuracy over Normal Range		D/A Accuracy % of span	Digital Accuracy over Maximum Range		Standards <small>(All IEC referenced sensors use the ITS-90 temperature scale)</small>
	°C	(°F)		°C	(°F)	
Pt100	0.15C	for -200 to 450 (-328 to 842)	0.025%	0.25C	for -200 to 850C (-328 to 1562)	IEC 60751 ($\alpha=0.00385$)
Pt200	0.30C	for -200 to 450 (-328 to 842)	0.025%	0.40C	for -200 to 850C (-328 to 1562)	IEC 60751 ($\alpha=0.00385$)
Pt100J	0.15C	for -200 to 450 (-328 to 842)	0.025%	0.25C	for -200 to 640C (-328 to 1184)	JISC1604-81($\alpha=0.00392$)
Ω	0.40 Ω for 0 to 1000 Ω		0.025%	0.40 Ω for 0 to 1,000 Ω		
mV	15 μ V for -20 to 120mV		0.025%	15 μ V for -20 to 120mV		
B	1.0C	for 550 to 1820 (1022 to 3308)	0.025%	3.0C	for 200 to 1,820C (392 to 3308)	IEC 60584-1
E	0.30C	for 0 to 1000 (32 to 1832)	0.025%	0.60C	for -200 to 1,000C (-328 to 1832)	IEC 60584-1
J	0.30C	for 0 to 800 (32 to 1472)	0.025%	0.70C	for -200 to 1,200C (-328 to 2192)	IEC 60584-1
K	0.60C	for -120 to 1370 (-191 to 2498)	0.025%	0.90C	for -200 to 1370C (-328 to 2498)	IEC 60584-1
N	0.40C	for 0 to 1300 (32 to 2372)	0.025%	1.5C	for -200 to 1300C (-328 to 2372)	IEC 60584-1
R	0.60C	for 500 to 1760 (932 to 3200)	0.025%	1.0C	for -50 to 1760C (-58 to 3200)	IEC 60584-1
S	0.60C	for 500 to 1760 (932 to 3200)	0.025%	1.0C	for -50 to 1760C (-58 to 3200)	IEC 60584-1
T	0.30C	for -100 to 400 (-148 to 752)	0.025%	0.5C	for -250 to 400C (-418 to 752)	IEC 60584-1

SPECIFICATIONS

Operating Conditions

Parameter	Reference Condition	Rated Condition	Operative Limits	Transportation And Storage
Ambient temperature °C	23 °C \pm 2	-40 to +85	-40 to +85	-50 to +100
Humidity				
Rack mounted % RH	10 to 55	5 to 95	5 to 100	5 to 100
In field housing % RH	10 to 55	5 to 100	5 to 100	5 to 100
Supply voltage	Voltage range 10.8 to 35 Vdc at the transmitter terminals			
Output current	Current overrange 3.8 to 20.8 mA. Failsafe limits < 3.8 and 21.8 mA			
Load resistance	0 to 1110 Ω			
Vibration	Maximum of 4g over 15 to 200Hz (restricted to 3g with indication meter).			
Shock	Maximum of 40g.			

Performance Specifications

Output D/A accuracy: $\pm 0.025\%$ of span

Cold Junction accuracy: $\pm 0.5^\circ\text{C}$

Total reference accuracy: Analogue 4-20mA mode = Digital accuracy + Output D/A accuracy + CJ accuracy (T/Cs only)

Total reference accuracy: Digital DE mode = Digital accuracy + CJ accuracy (T/Cs only).

(example: transmitter operating in analogue mode with Pt100 sensor and 0 to 200°C range.

Total reference accuracy = $0.15 + (200/100) * 0.025 = 0.2^\circ\text{C}$.

Digital ambient temperature effect (per 10°C change from 23°C ref.): RTDs or Ohms : 0.050% of reading in Ohms. : T/Cs or mV : 0.080% of reading in mV.

Output D/A ambient temp. effect (per 10°C change from 23°C ref.): $\pm 0.045\%$ of span.

Cold Junction ambient temperature effect: 40: 1 rejection for ambient temperature changes from 23°C reference.

Total output ambient temperature effect : Analogue 4-20mA mode = Digital effect + Output D/A effect + CJ effect (T/Cs only).

Total output ambient temperature effect: Digital DE mA mode = Digital effect + CJ effect (T/Cs only).

Power supply voltage effect: 0.005% of Max span per Volt.

Stability/time drift: 0.05% of max span per year.

Additional Parameters

Output: 4-20mA or Honeywell digital DE protocol. HART and DE available with 4-20mA output.

Adjustment range: No limits to adjustments within the Maximum Range except minimum span limit of 1 engineering unit e.g. 1°C

Damping time constant: Adjustable from 0 to 102 seconds digital damping.

Output response time: 1 second to reach 63% of final value with 0 secs damping.

Output update time

0.5 secs approximately.

Input/ output galvanic isolation Withstands 500Vac dielectric strength test for 1 minute.

Sensor open circuit

Open circuit/ burnout detection is user selectable. Upscale or downscale with critical status message. Latching or non-latching sensor burnout action.

Common mode rejection

120dB (1 million to 1) from 50Hz to 50 kHz.

Series mode rejection

40dB (100 to 1) for 50 or 60Hz $\pm 0.5\text{Hz}$. (with internal software filter set to local power line frequency).

EMC compliance

In compliance with 89/336/EEC, ElectroMagnetic Compatibility (EMC) Directive.

RFI rejection: $\pm 0.1\%$ of span at 30V/m over 20 to 1,000MHz in metallic housing and with shielded cables.

Physical Mounting, Construction and Integral Meters

The STT250 Temperature Transmitter is designed to be mounted in a DIN Form A housing for direct installation with the temperature sensor or can be provided in a remote pipe or wall mount housing. Details on the various housings and integral meters available are given in specification sheet EN01-6032. The STT250 Temperature Transmitter module can also be DIN rail mounted to a top hat or “G” rail via a clip.

STT250 Module Dimensions (in mm)

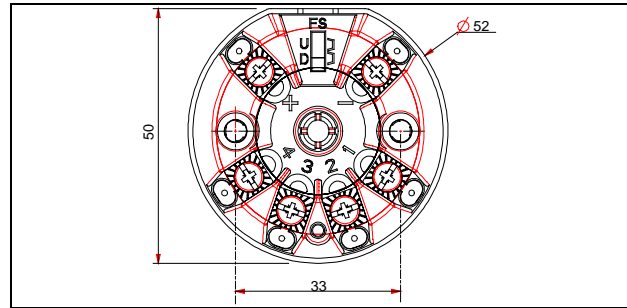
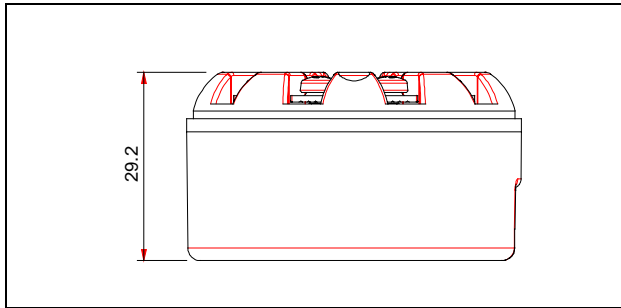

STT250 Connections

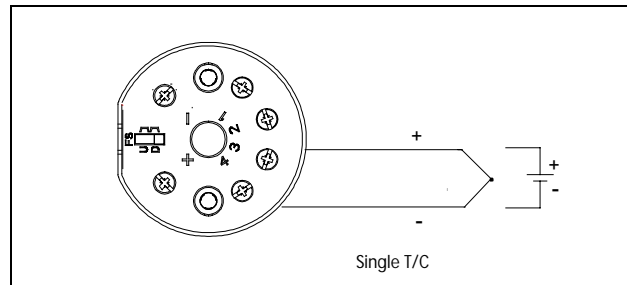
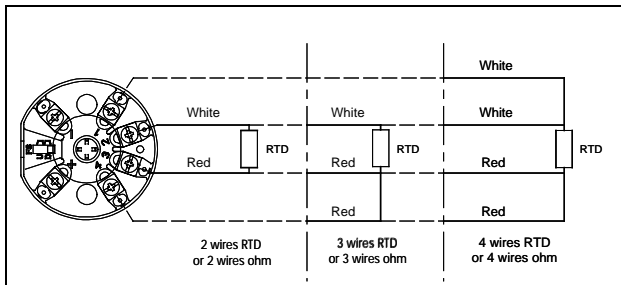

Materials of Construction

Terminal Block	Noryl
Connection Screws	M3 Nickel plated brass
Module Housing	Cyclopol (PC/ABS) with metallised interior surface
Weight	0.075 kg (0.2 lbs)

Approvals

The STT250 Temperature Transmitter module is Intrinsically Safe to Cenelec, FM and CSA standards when used with a suitable safety barrier. It is zone 2 and explosion-proof to Cenelec, FM and CSA standards when installed in a suitable housing. See the Model Selection Guide Table VII in this Specification Sheet for detailed safety approvals covering both the STT250 module only or for the STT250 module supplied in a housing.

Probe and Thermowell Availability

STT250 can be supplied complete with any of the previously listed thermocouple or RTD sensors and with any of a wide range of thermowells. The sensors are of Mineral Insulated (MI) construction with lengths of up to 2 meters available. For the direct head mount installation the sensor is supplied with a mounting plate for STT250 module attachment and fixing screws to provide the spring loaded attachment to the housing. For EEx d IIC T6 applications a flame trap is included between the sensor and sensor entry of the housing. See details on the standard sensors available in EN01-6033 for Europe, or 34-44-29-01 for North America.

The range of thermowells available as a total thermal solution cover almost every possible requirement :

Materials:	Carbon Steel, 304SS, 316SS, 316L SS, Hastelloy C-276, Monel 400, Inconel, and many others
Thermowell Types:	Threaded or flanged, with or without lagging and solid drilled, forged or fabricated construction
Flange Types:	Raised Face, Flat Face and Ring Type joint flanges available in 1 to 3 inch sizes or 15 to 200mm
Flange Ratings:	ANSI 150 to 2500, BS 4504 NP6 to NP100, BS 10 Tables D to K and API 6A 5000 to 15000lb

Other materials, types and accessories are available on request.

TABLE IV Optional Equipment

Mounting	No mounting bracket	0 - -	●	Amiens
	Carbon steel pipe mounting bracket for 2" pipe	M - -	a	
	Stainless Steel mounting bracket for 2" pipe	S - -	a	
	Spring loading mounting set	L - -	c	
	DIN rail mounting clip (top hat or G rail)	D - -	g	
M20 adaptors	No adaptors required	- 0 -	●	
	1 adaptor for M20 x 1.5 wiring entry	- 1 -	a, f	
	2 adaptors for M20 x 1.5 wiring entry	- 2 -	a, f	
3/4" NPT adaptors	1 adaptor for 3/4" NPT wiring entry	- 3 -	a, f	
	2 adaptors for 3/4" NPT wiring entry	- 4 -	a, f	
Lightning Protection	No lightning protection supplied	- - 0	●	
	Internal surge / Lightning protection	- - S	a, k	
	External lightning protection	- - L	a, j	

TABLE V Optional Extended Warranty Coverage and Certification

Standard warranty	0 - -	●
Additional warranty - 1 year	1 - -	●
Additional warranty - 2 years	2 - -	●
Additional warranty - 3 years	3 - -	●
Additional warranty - 4 years	4 - -	●
Additional warranty - 5 years	5 - -	●
No transmitter configuration / calibration certificate	- 0 -	●
Transmitter configuration / calibration certificate	- D -	●
No certificate of conformance or statement of origin	- - 0	●
Certificate of conformance and statement of origin	- - C	●

TABLE VI Additional Features

No selection	0 0	●	Amiens
Use STT 3000 Special / Additional features MSG for appropriate code	X X	●	

TABLE VII Safety Approvals

No approvals		0 0	●			
CENELEC Intrinsic Safety	EEx ia IIC T6/T5/T4	3 S	●			
CENELEC Flame Proof	EEx d IIC T6	3 D	d			
Non-Sparking certification for Zone 2	T6, 30V/22mA	3 N	b			
FM	Explosion proof	Class I, Div 1, Groups A, B, C, D	1C	e		
	Dust Ignition Proof	Class II, III, Div 1, Groups E, F, G				
	Intrinsically Safe	Class I, II, III, Div 1, Groups A-G				
	Non-Incendive	Class I, Div 2, Groups A, B, C, D				
	Outdoor Location	Suitable for Class II, III, Div 2, Groups F, G				
	NEMA 4X					
	Explosion proof	Class I, Div 1, Groups B, C, D	1J	a		
	Dust Ignition Proof	Class II, III, Div 1, Groups E, F, G				
	Intrinsically Safe	Class I, II, III, Div 1, Groups A-G				
	Non-incendive	Class I, Div 2, Groups A, B, C, D				
	Outdoor Location	Suitable for Class II, III, Div 2, Groups F, G				
	NEMA 4X					
CSA	Intrinsically Safe	Class I, II, III, Div 1, Groups A, B, C, D, E, F, G	1G	a		
	Non-incendive	Class I, Div 2, Groups A, B, C, D				
	Explosion proof	Suitable for Class II, III, Div 2, Groups F, G				
	Outdoor Location	NEMA 4X				
	Intrinsically Safe	Class I, Div 1, Groups A, B, C, D			1G	g
	Non-incendive	Class I, Div 2, Groups A, B, C, D				
	Explosion proof	Class I, Div 1, Groups B, C, D				
	Dust ignition proof	Class II, III, Div 1, Groups E, F, G	2J	a		
	Intrinsically safe	Suitable for Class I, II, III, Div 2, Groups A, B, C, D, E, F, G				
	Outdoor Location	Class I, II, III, Div 1, Groups A-G				
	Intrinsically safe	Enclosure Type 4X				
	Intrinsically safe	Class I, II, III, Div 1, Groups A-G			2 S	a
Outdoor Location	Suitable for Class I, II, III, Div 2, Groups A, B, C, D, E, F, G					
Enclosure Type 4X						

Intrinsically safe	Class I, Div 1, Groups A, B, C, D	2 S	g
--------------------	-----------------------------------	-----	---

Restrictions

a	Available only with Table II selections E - -, X - - or T - -
b	Not available with Table II selection 0 - -
c	Not available with Table II selections E - -, X - - or T - -
d	Available only with Table II selections E - -, X - - or T - - OR with Table I selection 1 and Table II selection B - -
e	Available only with Table II selections EN0, XN0 or TN0
f	Not available with Table IV selection - - L, or with Table VII selection 2J
g	Available only with Table II selection 0 0 0
j	Not available with Table VII selection 3D
k	Not available with Table VII selection 2J, 2S (CSA approvals – pending)

Distributor :

Honeywell

Industrial Automation and Control

Helping You Control Your World

Honeywell Inc.

- In the U.S.A.: Honeywell Industrial Automation and Control, 16404 North Black Canyon Hwy., Phoenix, AZ 85023, (602) 313-5000
- In Europe: Honeywell PACE, 1 Avenue du Bourget, B-1140 Brussels, Belgium, (32) 2-728-211
Honeywell S.A., Zone Industrielle de Longpré, F-80084 Amiens Cédex 2, France, (33-3) 22-54-56-56
- In Asia: Honeywell Asia Pacific Inc., N° 19, Toa Payoh, Lorong 8 #06-00, Singapore 1231, 354-6768
- In the Mediterranean: Africa & Middle East Region, Honeywell SpA, Via Vittor Pisani 13, 20124 Milano, Italy, (39-2) 67731
- In Canada: The Honeywell Centre, 155 Gordon Baker Rd., North York, Ontario M2H 3N7, 1-800-461-0013
- In Latin America: Honeywell Inc., 14505 Commerce Way, Suite 500, Miami Lakes, Florida 33016-1556, (305) 3642300

5. OPERATING PRINCIPLE AND CONSTRUCTION

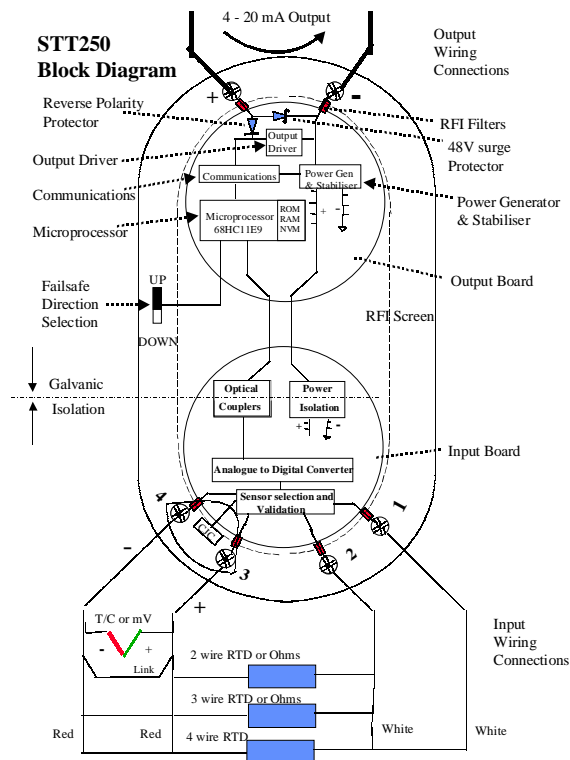

The input sensor (RTD or thermocouple) or input signal (mV or ohm) is connected to an analog to digital converter.

In case the automatic cold junction compensation has been selected, the cold junction temperature (i.e. the temperature of the connection screws) is measured with an internal thermocouple.

A voltage, based upon the measured cold junction temperature is subtracted from the voltage coming from the thermocouple sensor.

The resulting analog signal is converted to digital information by the Analog-to Digital circuitry.

After computations like linearization, correction and checks on validity and correctness of the signal, the digital information is converted to both a HART signal and a 4 .. 20 mA signal. Both signals are available on the current loop connections.

6 TEST METHODS AND REFERENCES

6.1 Test methods

6.1.1 Test set up

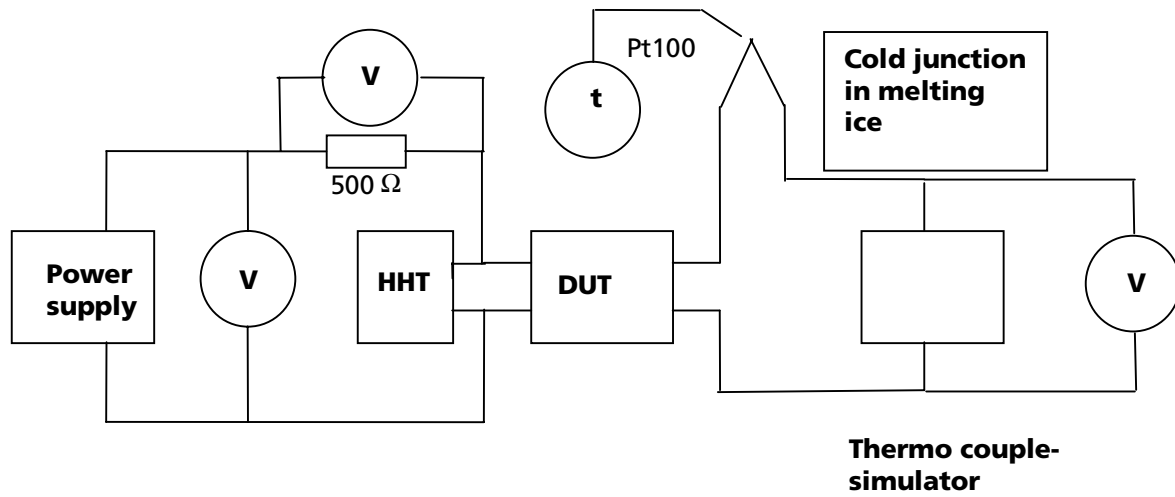

Fig 1: General test set up thermocouple transmitter application

Declaration:

HHT = hand held terminal

V = volt meter = temperature meter

Pt100 = temperature sensor for measuring the cold junction temperature

DUT = device under test

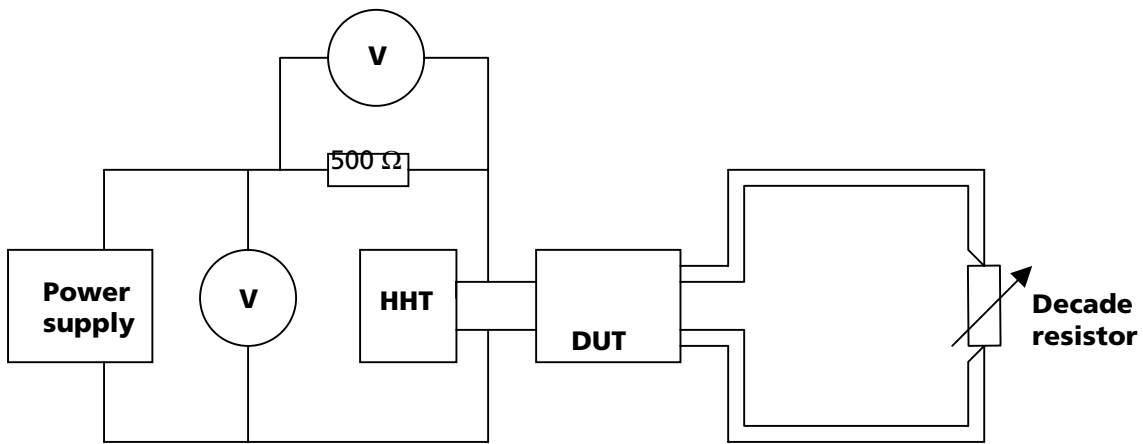

Fig 2: General test set up RTD transmitter application

Declaration:

HHT = hand held terminal

V = volt meter

DUT = device under test

During the evaluation the following instruments were used:

Temperature transmitter (long term test)	Make Honeywell; type STT25H; serial number 2409.
Temperature transmitter (Pt100 application during temperature test and humidity test)	Make Honeywell; type STT25H; serial number 2429.
Temperature transmitter (accuracy test with Pt100 configuration and with thermocouple configuration for range $-180\text{ }^{\circ}\text{C} \dots 760\text{ }^{\circ}\text{C}$; open/short circuit test; line resistance effect; power supply interruptions and depressions; earthing; start-up drift and over ranging)	Make Honeywell; type STT25H; serial number 16000.
Temperature transmitter (all other tests)	Make Honeywell; type STT25H; serial number 2439.
Multimeter, for temperature reading	Make Prema; type 6001; serial number 11747
Multimeter, for voltage reading of input voltage	Make Prema; type 5017; serial number 11144
Multimeter, for voltage reading across output resistor	Make Prema; type 5017; serial number 11099
Multimeter, for power supply voltage monitoring	Make Keithly; type 175; serial number 236861
Thermocouple simulator	Make Ectron, type 1120, serial number E-3-51729
Power supply	Make Delta; type E030-3; serial number 7750
Power supply	Make Delta; type E030-3; serial number 7751
Power supply (long term test only)	Make Delta; type MT24-12HE; serial number 6348
Resistance bank	Make Burster; type 1408; serial number 51179
Resistance bank	Make Burster; type 1405; serial number 49045
Impulse generator	Make Hewlett Packard; type HP 8011A; serial number 2111A 15653
Events counter	Make Hewlett Packard; type HP 5315A; s.n 2204A08574
Recorder	Make Kipp; type BD41; serial number 4182342
Hand held terminal	Make Fisher Rosemount; type 275; serial number 9834-1135M
Temperature / Humidity meter	Make Novasina; type MS1
Sine wave generator	Make Hewlett Packard, type 3314, serial number 2414A00349

Uncertainty estimation thermocouple transmitter measurement

For all ranges, the worst case estimated rms uncertainty of the measurements was:

Digital output: 0.030 % of reading \pm 7 mK.

Analog output: 0.030 % of reading \pm 7 mK.

Uncertainty estimation RTD transmitter measurements

The estimated worst case rms uncertainty of the measurements was:

Minimum measuring range 0 °C to 20 °C (accuracy measurements and most other measurements):

Digital output: 0.004 % of reading \pm 1 mK; mA output: 0.005 % of reading.

Range 0 °C to 100 °C (accuracy measurements only):

Digital output: 0.004 % of reading \pm 1 mK; mA output: 0.005 % of reading.

Measuring range -200 °C to 850 °C (accuracy measurements only):

Digital output: 0.006 % of reading \pm 1 mK; mA output: 0.006 % of reading.

Description of the test

Thermocouple type J input

for accuracy tests: 0 ... 40 °C, 0 ... 500 °C, -180 ... +760 °C,

For other tests: 0 ... 50 °C, ($\Delta U = 2585 \mu\text{V}$).

RTD, Pt 100 input

For accuracy tests: 0 ... 20 °C, 0 ... 100 °, -200 ... 850 °

for other tests: 0 ... 20 °, ($\Delta R = 7.79 \Omega$)

6.1.2 Test programme

The next diagram gives an overview of the tests to be applied. The checks and measurements to be carried out and the characteristic values calculated from them are described in more detail in Chapters 6.1.3 and 6.1.4 respectively.

Test	t	P	A	B	C	D	E	F	G	H
1 accuracy	x	x	x							
2 dead band	x	x								
3 open/short circuited input	x	x						x	x	
4 line resistance effect	x	x		x				x	x	
5 output load	x			x				x		
6 series mode interface	x				x		x		x	
7 common mode	omitted									
8 power supply variations	x			x						
9 power supply interruptions	x					x		x	x	x
10 power supply depressions	x					x		x	x	x
11 earthing	x			x		x		x	x	
12 ambient temperature	x	x		x					x	x
13 humidity	x			x					x	x
14 vibration	omitted									
15 start-up drift	x					x				
16 long term drift	x	x				x			x	
17 ripple content of output	x						x			
18 over ranging	x			x				x	x	x
19 step response	x									
20 power supply reversal	x			x				x	x	x
-- installation, maintenance, repair, adjustment, identification	x							x	x	
EMC										
21 high frequency disturbance test	omitted									
22 magnetic field interference	omitted									
23 electrostatic discharges	omitted									
24 radio frequency interference	omitted									

Measurement	Test	Measurement	Test
t	test tc-input	D	transient effects
P	test RD input	E	AC component on the output
A	I/O characteristic	F	message on the interface system
B	zero/span during and /or after test	G	qualitative observations during the test
C	shift at 10%, 50%, 90% of span	H	qualitative observations during the test

6.1.3 Description of the tests

Standard tests

Besides the 4...20 mA output signal, the digital information will be collected and verified for all measurements, as far as applicable, e.g. measured value, other values.

1 Accuracy

The measurements will be carried out three times with intervals of 10 % for rising and falling inputs, separately. From the measurements the I/O characteristic will be determined, as far as possible, of:

- The complete instrument (temperature input versus current output)
- The input block (temperature input versus digitized input)
- The output block (manual input command versus current output)

In addition, the accuracy of the output block (manual output command versus output current) will be determined.

2 Dead band

The largest change of input that can be effected without causing a detectable change of output will be determined at 10 % and 90 % input. This test will be carried out for all ranges of the accuracy test.

3 Open/short circuited input

The effect of open/short circuited input terminals will be determined.

In case of multi-variable input, the hot backup feature will be tested, including bumpless transfer.

4 Line resistance effect

TC input: The effect of a resistance of 1000 Ω in the TC input circuit will be determined. The resistance in the Fe-line will be 200 Ω , the resistance in the CuNi-line will be 800 Ω .

RTD input: The effect of a resistance of 50 $\Omega \pm 0,01 \%$ in each input line will be determined. The test will be repeated for the maximum line resistance specified by the manufacturer if different from 50 Ω .

5 Output load

The supply voltage applied will be adjusted to the maximum value. The load resistance of the instrument will be varied from 10 Ω to the maximum value.

The effects of connecting and disconnecting the modem will also be determined for resistances above 250 Ω . The smallest load will be determined at which the modem still operates.

6 Series mode interference

A series mode voltage of maximum 1 V peak, 50 Hz, (0,7 Vrms) will be applied across a 10 Ω resistance in series with an input signal of 50 %. The rms voltage will be determined at which the mean dc shift is 0,1 % and 5 %. Also, the rms voltage will be determined at which the peak of the ripple on the output is 0,5 %, 1 % and 5 %, as far as applicable.

7 Common mode

An a.c. voltage of 250 V r.m.s., 50 Hz, (or the maximum value specified by the manufacturer, if less) will be applied, in turn, between the earth connection and the input terminals and between the earth connection and output terminals. During the test, the instrument will be supplied from a battery, isolated from earth.

The test will be repeated with a 50 Vd.c. signal (or the maximum value specified by the manufacturer, if less).

During the test, the input will be 50 %.

8 Power supply variations

The output load will be adjusted to 250 Ω . The supply voltage will be varied from the minimum value to the maximum value specified at this load.

9 Power supply interruption

The power supply will be interrupted for maximum 500 ms and the start-up time behaviour will be determined.

10 Power supply depression

The power supply voltage will be depressed to values between 24 V and 0 V during 5...500 ms. Effects will be determined at an input of 100 %. The load will be the maximum value at 24 V.

11 Earthing

Each input and output terminal will, in turn, be connected to earth. If applicable, both for the modem plus PC will be connected and disconnected from the instrument output.

12 Ambient temperature

The instrument will be subjected to the following ambient temperatures: + 20/ + 40/ + 60/ + 85/ + 20/ + 0/ -20/ -40/ + 20 °C. The rate of change will be 1/3 K/min. After a dwell time of at least 3 hours at each temperature the output will be determined at 20 % steps of the input. A second temperature cycle, identical to the first, will be performed without re-adjustment of the instrument. From the measurements the shifts will be determined, as far as possible, of:

- The complete instrument (temperature input versus current output).
- The input block (temperature input versus digitised input).
- The output block (manual output command versus output current).

13 Ambient humidity

The instrument will be maintained at 40 °C and a relative humidity of not less than 95 % for a period of at least 2 days. The instrument will be switched on for the final 4 h of the above period. With the transmitter still in operation the temperature and humidity will be allowed to fall to the reference conditions. From the measurements the shift will be determined, as far as possible, of:

- The complete instrument (temperature input versus current output).
- The input block (temperature input versus digitised input).
- The output block (manual output command versus output current).

14 Vibration

Note: The test is not applicable for head mounted instruments without enclosure.

The instrument will be vibrated in three directions, perpendicular to the instrument's main axes, in the range 5...500 Hz. In the range 5...60 Hz the amplitude will be 0,07 mm. In the range 60...500 Hz the acceleration will be 1 g. The sweep rate will be 0,5 octave per minute.

During the test, the input will be 50 % and the output will be recorded. Resonance frequencies and their G-factor will be noted for each direction.

15 Start-up drift

The instrument will be subjected to reference conditions for a period of 24 hour with the power supply switched off. Then, with a 10 % input signal applied to the instrument, the supply will be switched on. The output signal will be noted after 5 min. and after 1 hour. The test will be repeated with a 90 % input signal.

16 Long term drift

The instrument will be operated for 30 days with a steady 90 % input signal. The output will be measured daily.

17 Ripple content of output

The peak-to-peak value and the main frequency component of any a.c. ripple content of the output will be measured with 10 % , 50 % and 90 % input signals.

18 Over ranging

An over range signal of 1 Vdc will be applied to the input terminals for 1 min. A recovery period of 5 min. will be allowed.

19 Step response

Input steps between 45 % and 55 % and between 10 % and 90 % of span will be applied up and down. The time taken for the output to reach and remain within 1 % of span of its final steady value will be measured for each test condition. Test to be done with the time constant set to minimum.

20 Power supply reversal

The effects of incorrect connection of the power supply wires during 1 minute will be determined.

--- Constructional aspects

Comments will be given on procedures for installation, maintenance, adjustment and repair. The manufacturer's documentation will be examined. Any identification difficulties and/or ambiguities will be noted. The accuracy of the range setting on the interface will be checked before and after the evaluation.

EMC tests

- The severity levels for the EMC tests will be in accordance with the current CE demands of EN 50082-2: Immunity in industrial environment.
- The effects, both during and after application of the disturbance, will be noted as indicated in the EN Standard under 'Performance criterion A'.
- During the EMC tests, the instrument will be supplied from a battery, isolated from earth.

21 Fast transients

Fast transients, according to IEC 1000-4-4, will be applied to the supply/output lines via the capacitive clamp. During the test, the input will be 50 %.

22 Magnetic field interference

The instrument will be subjected to a magnetic field of 50 Hz in accordance with IEC 1000-4-8. During the test, the input will be 50 %.

23 Electrostatic discharges

Electrostatic discharges in accordance with IEC 1000-4-2 will be applied to metal parts of the transmitter most likely to be touched by personnel during normal operation. During the test, the input will be 50 %.

24 HF interference

Before the test, two types of temperature transmitters have to be distinguished:

- A) Transmitters, designed for application of a thermowell, mounted directly to the instrument's enclosure. The thermowell screens the input leads from external fields. The sensor wires are short.
- B) Other transmitters.
- Ad A) Simulation of the temperature sensor will take place directly at the transmitter terminals: a short-circuit for TC input (measured value: ambient temperature); and an 103,9 Ω resistor for RTD input (measured value: + 10 °C).
- Ad B) Simulation of the temperature sensor will take place 1 m away from the instrument: short-circuit for TC input and an 103,9 Ω resistor for RTD input. The screening of the input lead will be in accordance with the manufacturer's requirements. If not specified: no screening will be applied.

During the test, the input will be 50 %. Transient shifts of the output signal at the various frequencies will be determined.

Conducted interference: The test will be carried out as described in IEC 1000-4-6. For transmitters of type A, the test will be carried out for output lines only.

Radiated interference: The test will be carried out as described in IEC 1000-4-3.

6.1.4 Test protocol

Various characteristics values will be calculated from the measurements.

A. I/O characteristic

From the measured values and output values the following will be determined.

- The average errors. The arithmetic mean of errors at each point of measurement, for rising and falling inputs separately.
- The hysteresis error. The maximum deviation between the two calibration curves of the measured variable as obtained by traversing upscale and downscale over the full range.
- The repeatability error. The algebraic difference between the extreme values obtained by a number of consecutive output measurements for the same value of the input under the same operating conditions, approaching from the same direction traversing the full range.

B. Zero shift/span shift during and/or after the test

The shift of the lower range value (zero shift) will be determined as well as the change of the algebraic difference between the lower range value and the upper range value (span shift).

C. Steady state shift

When applying a steady state input (either 10 %, 50 % or 90 % as mentioned under the relevant test) the output shift will be determined.

D. Transient effects

The amplitude, polarity and duration of the transients on the output will be determined as far as possible.

E. A.C. component (ripple) on output

The peak-to-peak and the principal frequency of any a.c. ripple content of the output will be determined, both with modem plus associated equipment (PC) connected and disconnected.

F. Messages on the PC

Messages at associated equipment, if applicable, will be noted.

G. Qualitative observation during the test

The operational behaviour of the instrument and the software programme will be observed during the test. Any irregularities caused by the tests applied will be noted.

H. Qualitative observation after the test

After the test, the instrument will be inspected for mechanical damage, damage to the electronics, accumulation of moisture or dust etc.

6.2 References

- IEC 770 Methods for evaluating the performance of transmitters for use in industrial process control systems.
- IEC 68 Basic environmental testing procedures.
- IEC 1000-4-x Electromagnetic compatibility (EMC), Part 4: Testing and measurement techniques
- IEC 751 Industrial platinum resistance thermometer sensors + A2:1995. (ITS-90)
- IEC 584-1 Thermocouples, part 1: Reference tables. (ITS-90)
- EN 50082-2 Electromagnetic compatibility, Generic immunity standard, Part 2: Industrial environment
- WIB Reports:
- M 2563 T 92 Test Specifications for I/O circuits of process control systems
- M 2654 T 97 Guideline for EMC-Immunity Testing of Instruments and Systems for Industrial Process Measurement and Control

6.3 Definitions

Error (IEC 902)

The algebraic difference between the measured value and the true value of the measured variable.

Note: The error is positive when the measured value is greater than the true value.

Average error

The arithmetic mean of the errors at each point of measurement, for rising and falling inputs separately.

Repeatability (IEC draft standard, reference 1, IEV 301, 302, 303, Sec. 1386) The ability of a measuring instrument to provide closely similar indications for repeated applications of the same measurand under the same conditions of measurement. In this report repeatability is expressed as twice the standard deviation of the errors from the average error at each point of measurement, for rising and falling inputs separately and calculated using the 'non-biased' or 'n-1' method.

Hysteresis error (IEC 902) The maximum deviation between the two calibration curves of the measured variable as obtained by an upscale going traverse and a downscale going traverse over the full range and subtracting the value of the dead band.

Dead band (IEC 902)

Finite range of values within which variation of the input variable does not produce any noticeable change in the output variable. Note: For a device with digital output representation, the dead band is the smallest change in the analogue of the input signal which always causes a change in the digital output.

Linearity error (IEC 902)

The absolute value of maximum deviation between the calibration curve and the specified straight line.

Shift (derived from IEC 902)

The change in output value caused by a specified influence.

Zero shift (IEC 902)

The change of the output value, due to some influences, when the input variable is at the lower range value.

Span shift (IEC 902)

The change in output span due to some influences.

Drift (IEC 902)

An undesired gradual change in the input-output relationship of a device over a period of time, not caused by external influences on the device.

Range (IEC 902)

The region of the values between the lower and upper limits of the quantity under consideration.

Uncertainty of measurement (BS 5233)

An estimate characterizing the range of values within which the true value of a measurand lies (The uncertainties quoted are for a confidence probability of not less than 95 %.)

Discrimination (BS 5233)

The ability of a measuring instrument to respond to small changes in the value of the stimulus.

Appendix

- Information on Quality Assurance
- General information relating to the instrument
- Manufacturer's Comments

Quality Assurance and Instrument Status

1. Quality Assurance

CERTIFICAT  **CERTIFICATE**

N° QUAL/1992/697

AFAQ certifie que le système qualité adopté par,
AFAQ certifies that the quality system developed by :

HONEYWELL SA

pour les activités suivantes,
for the following activities :

**CONCEPTION ET PRODUCTION D'ENREGISTREURS, DE REGULATEURS ET
D'EQUIPEMENTS INDUSTRIELS DE CONTROLE DE PROCÉDES ET DE
CONTROLEURS DE FLAMME.**

**DESIGN AND PRODUCTION OF RECORDERS, CONTROLLERS AND PROCESS
CONTROL INDUSTRIAL EQUIPMENT AND OF FLAME CONTROLLERS.**

exercées sur le(s) site(s) suivant(s),
carried out in the following location(s) :

ZI de Longpré F-80084 AMIENS CEDEX 2

a été évalué et jugé conforme aux exigences de la norme,
has been assessed and found to conform to the requirements of the standard :

ISO 9001 (1994)

Le présent certificat, délivré dans les conditions fixées par AFAQ, est valable à dater du,
This certificate, delivered under AFAQ rules, is valid as from :

1998-10-15

(année-mois-jour) jusqu'à / until **2001-09-16** (year-month-day)

Le PRÉSIDENT DU COMITÉ DE CERTIFICATION Le DIRECTEUR GÉNÉRAL D'AFAQ Le REPRÉSENTANT DE L'ENTREPRISE
The PRESIDENT OF THE CERTIFICATION COMMITTEE The Managing Director of AFAQ On BEHALF of the Firm

 **A. PIGEONNIER**  **O. PEYRAT**  **C. GUERS**

AFAQ - THE AVENUE WHITE STAR - BP 40 - F-92024 BAGNOLET CEDEX FRANCE

2. Information on the product evaluated by SIREP-WIB-EXERA

2.1 Production facilities and interchangeability of parts regardless of origin

The product is being produced at Honeywell's, France.
Only the final assembly of options can be also made at Phoenix, Arizona, USA. All the parts of the product are fully interchangeable regardless of the origin of the product.

2.2 Expected product lifetime

The expected product lifetime is 10 years.

2.3 Guarantee period

The guarantee period is 18 months as standard, up to 78 months on request.

2.4 Service/maintenance facilities and spare parts available after ceasing the product manufacturing

Spare parts are available 10 years after ceasing the product manufacturing.

2.5 Installation Manual languages available

Manuals are available in English, French, Chinese, Japanese and Spanish

Manufacturer's comments

The manufacturer has no formal comments to the report.